

**N**exans



**Standard hook-up wires  
and cables for Electronics  
Filotex®**



<b>Guideline of wires and cables .....</b>	<b>4</b>
<b>Part 1 - Standard coaxial cables .....</b>	<b>7</b>
KX & RG standard coaxial cables .....	9
FLAMEX Halogen free coaxial cables .....	15
Telecom coaxial cables.....	17
Low noise coaxial cables .....	21
Miniature coaxial cables.....	23
Hand formable coaxial cables .....	25
<b>Part 2 - Single core and multicore cables.....</b>	<b>27</b>
Operating temperature:	
80°C.....	28
105°C.....	47
150°C.....	69
200°C.....	79
250°C.....	91
<b>Part 3 - Hook-up wires for wrapping.....</b>	<b>97</b>
<b>Part 4 - Accessories .....</b>	<b>101</b>

*For imperative length, consult us.*

In addition to the standard products, you will find within this catalogue, our development and design engineers are at your disposal to provide their experience in tailoring any of our products to meet your specific requirements.

## Standard coaxial cables

Product range	Description	Page
<b>COAX KX / RG</b>	KX & RG standard coaxial cables	<b>9</b>
<b>COAX FLAMEX</b>	FLAMEX halogen free coaxial cables	<b>15</b>
<b>COAX TELECOMS</b>	Telecom coaxial cables	<b>17</b>
<b>CAS</b>	Low noise cables	<b>21</b>
<b>50 / 75 VMTX</b>	Miniature coaxial cables	<b>23</b>
<b>QUICKFORM®</b>	Hand formable coaxial cables	<b>25</b>

## Single core and multicore cables

Max. operating temp.	Insulation	Single cores	Multi-cores	Product range	Description	Page
<b>80°C</b>	PE / PVC	•		<b>HT</b>	High voltage hook-up wires	<b>29</b>
	PVC	•		<b>UL 1007</b>	UL qualified hook-up wires	<b>31</b>
		•	•	<b>FM &amp; FMA</b>	Screened and jacketed hook-up wires and multicore cables for low frequency applications	<b>33</b>
		•	•	<b>EHE &amp; EHEA</b>	Screened and jacketed hook-up wires and multicore cables for low frequency applications	<b>35</b>
			•	<b>SMA &amp; SMBL</b>	Unscreened and jacketed (SMA), Screened and jacketed (SMBL) multicore cables	<b>37</b>
			•	<b>GRTH &amp; CCTB</b>	Unscreened and jacketed (GRTH), Screened and jacketed (CCTB) multicore cables	<b>39</b>
			•	<b>G250</b>	Flexible pairs screened with overall braid	<b>41</b>
	ZERO HAL		•	<b>SMA-ZH SMBL-ZH</b>	Unscreened and jacketed (SMA-ZH), Screened and jacketed (SMBL-ZH) halogen free multicore cables	<b>43</b>
		•	<b>G250-ZH</b>	Halogen free flexible pairs screened with overall braid	<b>45</b>	
<b>105°C</b>	PVC	•		<b>UL 1015</b>	UL qualified hook-up wires	<b>49</b>
		•		<b>KY / EPDX</b>	Unscreened hook-up wires	<b>51</b>
		•		<b>KY / EPDX</b>	Screened hook-up wires, screened and jacketed hook-up wires	<b>53</b>
	PVC SUPERPOLYAMIDE	•		<b>1604</b>	Unscreened hook-up wires	<b>55</b>
		•	•	<b>604</b>	Screened and jacketed hook-up wires and multicore cables	<b>57</b>
		•		<b>1625 A</b>	Unscreened hook-up wires	<b>59</b>
	ZERO HAL	•		<b>FLAMEX 20</b>	Unscreened halogen free hook-up wires, Screened and jacketed hook-up wires	<b>61</b>
			•	<b>FLAMEX 20</b>	Screened and jacketed halogen free multicore cables	<b>63</b>
		•		<b>KY / EPDX ZH</b>	Halogen free unscreened hook-up wires	<b>67</b>

## Single core and multicore cables

Max. operating temp.	Insulation	Single cores	Muti-cores	Product range	Description	Page
<b>150°C</b>	FEP SUPERPOLY-AMIDE	•		<b>1806</b>	Unscreened hook-up wires	<b>71</b>
		•	•	<b>806</b>	Screened and jacketed hook-up wires and multicore cables	<b>73</b>
	ETFE	•	•	<b>KU</b>	Unscreened hook-up wires, pairs and triples	<b>75</b>
		•	•	<b>KU</b>	Screened and jacketed hook-up wires, pairs and triples	<b>77</b>
<b>200°C</b>	PTFE	•		<b>KZ</b>	Unscreened hook-up wires, high temperature	<b>81</b>
		•		<b>KZ</b>	Screened and jacketed hook-up wires, high temperature	<b>83</b>
			•	<b>KZ</b>	Screened and jacketed pairs, high temperature	<b>85</b>
			•	<b>KZ</b>	Screened and jacketed triples, high temperature	<b>87</b>
		•		<b>ETF, EF &amp; EEF</b>	Unscreened hook-up wires, high temperature	<b>89</b>
<b>250°C</b>	PTFE	•		<b>1900 A</b>	Flexible cables for high ambient temperatures, Light weight cables	<b>93</b>
	PTFE POLY-AMIDE	•		<b>2100</b>	Flexible cables for high ambient temperatures	<b>95</b>

## Hook-up wires for wrapping

Max. operating temp.	Insulation	Single cores	Muti-cores	Product range	Description	Page
<b>From 85°C to 200°C</b>	PVC	•		<b>WCP</b>	Hook-up wires for wires-wrapping	<b>99</b>
	ETFE	•		<b>WCZ</b>	Hook-up wires for wires-wrapping	<b>99</b>
	PTFE	•		<b>WCT</b>	Hook-up wires for wires-wrapping	<b>99</b>

## Accessories

Accessories	Product range	Description	Page
<b>BRAIDS</b>	<b>FITE</b>	Tinned copper flat braids	<b>103</b>
	<b>Tubular braids</b>	Tubular braids in tinned copper without filler	<b>105</b>
	<b>Tubular braids</b>	Tubular braids in tinned copper with filler	<b>107</b>
	<b>Tubular braids</b>	Tubular superpolyamide braids high temperature	<b>109</b>
<b>TUBES</b>	<b>PTFE tubes</b>	Extruded PTFE tubes	<b>111</b>

## Symbols

**Ambient Temperature**

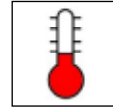

**Flexibility**



**Chemical attacks**

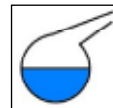

**Fire performances**



**Smoke density**



**Gases corrosivity**

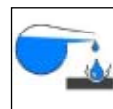

**Electro Magnetic Interference**



**Halogen free**



**ROHS compliant**

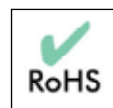

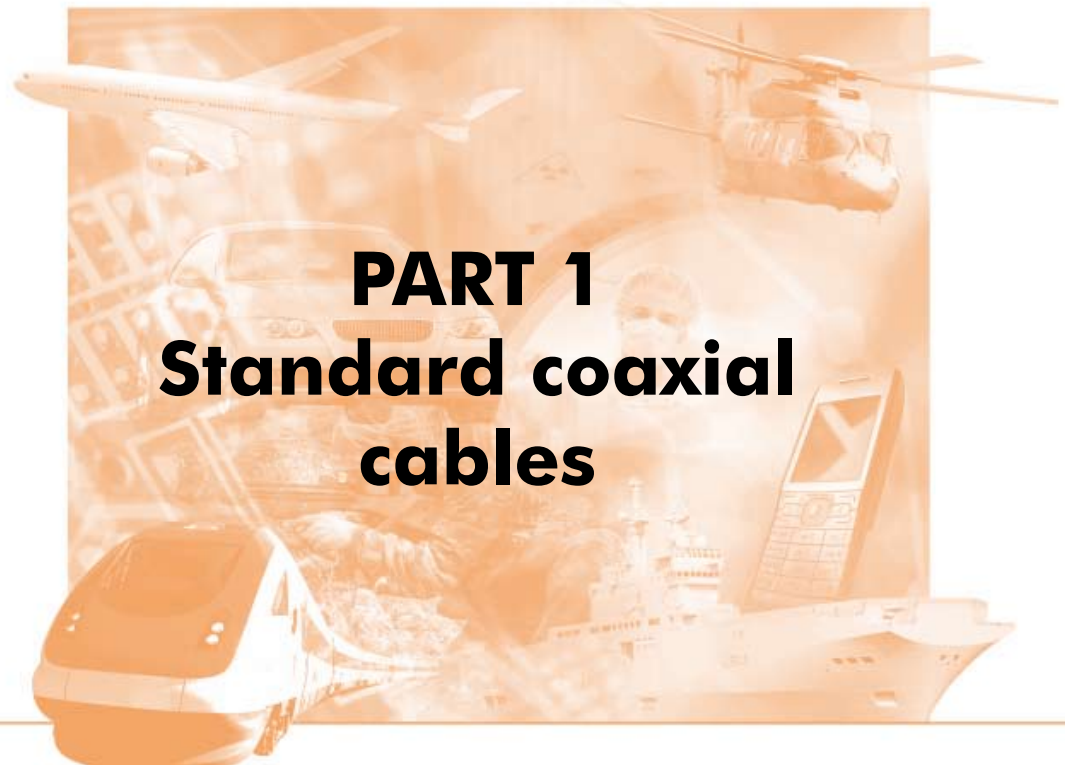

**PART 1**  
**Standard coaxial**  
**cables**



# KX & RG COAXIAL CABLES

KX/RG

## Applications

Coaxial cables for high frequency connections.

Coaxial cables from 50  $\Omega$  to 95  $\Omega$

## Construction

### 1- CONDUCTOR

Stranded or solid, in bare copper (BC), tin plated copper (TPC), silver plated copper (SPC), copper clad steel (CCS) or silver plated copper clad steel (SPCCS)

### 2- DIELECTRIC

PE or PTFE

### 3- SCREEN

Single or double braid in bare, tin plated or silver plated copper

### 4- SHEATH

PVC, FEP, PFA or glass fibre

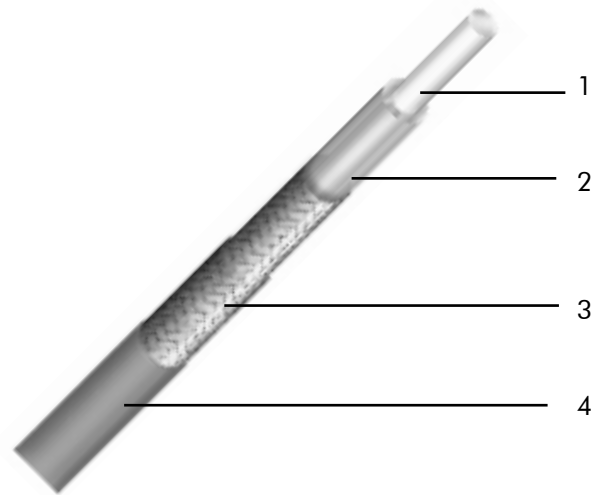

## Bending radius

5 x overall diameter (for most coaxial cables)

## Standards

MIL C17

NF C 93-550

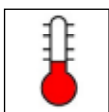

See on the following pages



See on the following pages



Flexible



RoHS

## 50 Ω KX & RG coaxial cables

Max. oper. temp.	References according to		Nexans ref.	Conductor			Dielectric Ø mm	Braids		Sheath		Av. weight kg/km	Application	
	Dielectric	NF C93-550		MIL C17	Composition n x mm	Nature		Ø mm	Nb	Nature	Nature			Overall Ø mm
85°C	PE	KX 3B		373095	7 x 0.16	CCS	0.48	1.50 ±0.10	1	TPC	PVC	2.54 ±0.13	10	①
			RG 174 AU	373171	7 x 0.16	CCS	0.48	1.52 ±0.08	1	TPC	PVC	2.79 ±0.13	12	①
		KX 15	RG 58 CU	373117	19 x 0.18	TPC	0.90	2.95 ±0.10	1	TPC	PVC	4.95 ±0.15	36	①
			RG 223 U	373184	1 x 0.89	SPC	0.89	2.95 ±0.10	2	SPC	PVC	5.38 ±0.10	55	①
		KX 4		373099	7 x 0.75	BC	2.25	7.25 ±0.15	1	BC	PVC	10.30 ±0.20	158	①
			RG 213 U	87023	7 x 0.75	BC	2.25	7.25 ±0.15	1	BC	PVC	10.30 ±0.20	158	①
		RG 214 U	373181	7 x 0.75	SPC	2.25	7.25 ±0.18	2	SPC	PVC	10.80 ±0.18	196	①	
200°C AND +	PTFE	KX 21 A		87126	7 x 0.10	SPCCS	0.30	0.87 ±0.07	1	SPC	FEP	1.80 ±0.10	9.6	②
			RG 178 BU (M17/169-00001)	87069	7 x 0.10	SPCCS	0.30	0.84 ±0.05	1	SPC	FEP	1.80 ±0.10	9.6	②
			RG 196 (M17/93-00001)	87247	7 x 0.10	SPCCS	0.30	0.84 ±0.05	1	SPC	PFA	1.80 ±0.10	9.6	②
		KX 22 A		87017	7 x 0.17	SPCCS	0.51	1.50 ±0.10	1	SPC	FEP	2.50 ±0.10	17	②
			RG 316 U (M17/172-00001)	85790	7 x 0.17	SPCCS	0.51	1.52 ±0.08	1	SPC	FEP	2.49 ±0.10	17	②
			RG 188 AU (M17/138-00001)	87245	7 x 0.17	SPCCS	0.51	1.52 ±0.08	1	SPC	PFA	2.49 ±0.10	17	②
			RG 142 AU	87009	1 x 0.94	SPCCS	0.94	2.95 ±0.13	2	SPC	Glass fiber	5.10 ±0.15	66	③
			RG 142 BU (M17/158-00001)	87066	1 x 0.94	SPCCS	0.94	2.95 ±0.13	2	SPC	FEP	4.95 ±0.13	68	③
			RG 400 U (M17/175-00001)	87125	19 x 0.20	SPC	0.98	2.95 ±0.13	2	SPC	FEP	4.95 ±0.13	66	③
		KX 23		87063	7 x 0.34	SPC	1.02	2.95 ±0.15	2	SPC	Glass fiber	5.10 ±0.20	70	③
			RG 393 (M17/174-00001)	85398	7 x 0.80	SPC	2.40	7.24 ±0.13	2	SPC	FEP	9.91 ±0.25	241	③
KX 24		87029	7 x 0.80	SPC	2.40	7.25 ±0.12	2	SPC	Glass fiber	10.90 ±0.25	216	③		

BC : bare copper

TPC : tin plated copper

SPC : silver plated copper

CCS : copper clad steel

SPCCS : silver plated copper clad steel

① High frequency connections.

② High frequency connections operating at high temperature. By their small dimensions, they are mainly designed for miniaturized connections, operating at high or low temperature.

## 50 Ω KX & RG coaxial cables

Oper. temperature Min / Max	Fire properties	Max. op. frequency GHz	Nominal capacitance pF/m	Attenuation (db/100m)				Dielectric strength kV	Powers at 40°C (kw)				Velocity of propagation	Continuous working voltage
				200 MHz	400 MHz	3000 MHz	10000 MHz		200 MHz	400 MHz	3000 MHz	10000 MHz		
-40 +85	NF C 32070/C2 IEC 60332-1&2	3	100.0	42	60	220		2	0.057	0.042	0.013		65.9	1100
-40 +85	NF C 32070/C2 IEC 60332-1&2	1	106.0	42	60	220		4.5	0.057	0.042	0.013		65.9	1100
-40 +85	NF C 32070/C2 IEC 60332-1&2	3	100.0	23	32	98		5	0.125	0.09	0.031		65.9	1400
-40 +85	NF C 32070/C2 IEC 60332-1&2	12.4	106.0	20	30	100	240	5	0.125	0.09	0.031	0.017	65.9	1400
-40 +85	NF C 32070/C2 IEC 60332-1&2	3	100.0	9.5	14.5	55		5	0.42	0.3	0.095	0.05	65.9	3700
-40 +85	NF C 32070/C2 IEC 60332-1&2	3	100.0	9.5	14.5	55		5	0.42	0.3	0.095	0.05	65.9	3700
-40 +85	NF C 32070/C2 IEC 60332-1&2	11	106.0	9	13	46	100	10	0.42	0.3	0.095	0.05	65.9	3700
-90 +200	NF C 32070/C1&C2 IEC 60332-1	3	95.0	65	95	300		1	0.085	0.057	0.018		69.5	750
-90 +200	NF C 32070/C1&C2 IEC 60332-1	3	105.0	58	80	225		2	0.085	0.057	0.018		69.5	750
-90 +230	NF C 32070/C1&C2 IEC 60332-1	3	105.0	58	80	225		2	0.085	0.057	0.018		69.5	750
-90 +200	NF C 32070/C1&C2 IEC 60332-1	3	95.0	40	55	160		2	0.17	0.11	0.032		69.5	900
-90 +200	NF C 32070/C1&C2 IEC 60332-1	3	105.0	40	55	160		2	0.17	0.11	0.032		69.5	900
-90 +230	NF C 32070/C1&C2 IEC 60332-1	3	105.0	40	55	160		2	0.17	0.11	0.032		69.5	900
-90 +250	NF C 32070/C1&C2 IEC 60332-1	3	95.0	19	27	79	163	5	0.66	0.45	0.15	0.08	69.5	1400
-90 +200	NF C 32070/C1&C2 IEC 60332-1	3	105.0	19	27	79	163	5	0.66	0.45	0.15	0.08	69.5	1400
-90 +200	NF C 32070/C1&C2 IEC 60332-1	3	105.0	20	29	89	185	5	0.66	0.45	0.15	0.08	69.5	1400
-90 +250	NF C 32070/C1&C2 IEC 60332-1	3	95.0	20	29	89	185	5	0.66	0.45	0.15	0.08	69.5	1400
-90 +200	NF C 32070/C1&C2 IEC 60332-1	11	105.0	9.3	14	47	109	4	2	1.3	0.43	0.22	69.5	3700
-90 +250	NF C 32070/C1&C2 IEC 60332-1	3	95.0	9.3	14	47	109	10	2	1.3	0.43	0.22	69.5	3700

③ High frequency connections operating at high temperature, or on equipment excepted to work under severe conditions without failure.

## 75 Ω KX & RG coaxial cables

Max. op. temp.	Dielectric	References according to		Nexans ref.	Conductor			Dielectric Ø mm	Braids		Sheath		Av. weight kg/km	Application
		NF C 93-550	MIL C17		Compo-sition n x Ø mm	Nature	Ø mm		Nb	Nature	Nature	Overall Ø mm		
85°C	PE		RG 59 BU	390650	1 x 0.58	CCS	0.58	3.71 ± 0.10	1	BC	PVC	6.15 ± 0.10	50	①
		KX 6A		373100	7 x 0.20	BC	0.60	3.70 ± 0.12	1	BC	PVC	6.10 ± 0.15	53	①
			RG 11 AU	373135	7 x 0.40	TPC	1.20	7.24 ± 0.18	1	BC	PVC	10.30 ± 0.18	136	①
			RG 216 U	373182	7 x 0.40	TPC	1.20	7.24 ± 0.18	2	BC	PVC	10.80 ± 0.18	177	①
		KX 8		373113	7 x 0.40	BC	1.20	7.25 ± 0.15	1	BC	PVC	10.30 ± 0.20	135	①
200°C and +	PTFE		RG 179 BU (M17/94-RG 179)	081997	7 x 0.10	SPCCS	0.30	1.60 ± 0.08	1	SPC	FEP	2.54 ± 0.13	16.9	②
			RG 187 AU (M17/136- 00001)	087244	7 x 0.10	SPCCS	0.30	1.60 ± 0.08	1	SPC	PFA	2.54 ± 0.13	16.9	②

## 93-95 Ω KX & RG coaxial cables

Max. op. temp.	Dielectric	References according to		Nexans ref.	Conductor			Dielectric Ø mm	Braids		Sheath		Av. weight kg/km	Application
		NF C 93-550	MIL C17		Compo-sition n x Ø mm	Nature	Ø mm		Nb	Nature	Nature	Overall Ø mm		

### 93 Ω

85°C	PE		RG 62 AU	373148	1 x 0.64	CCS	0.64	3.71 ± 0.13	1	BC	PVC	6.15 ± 0.18	46	①
------	----	--	----------	--------	----------	-----	------	----------------	---	----	-----	----------------	----	---

### 95 Ω

200°C and +	PTFE		RG 180 BU (M17/95-RG 180)	087241	7 x 0.10	SPCCS	0.30	2.59 ± 0.08	1	SPC	FEP	3.58 ± 0.10	27	②
			RG 195 AU (M17/137- 00001)	087246	7 x 0.10	SPCCS	0.30	2.59 ± 0.08	1	SPC	PFA	3.58 ± 0.10	27	②

BC : bare copper  
 TPC : tin plated copper  
 SPC : silver plated copper  
 CCS : copper clad steel  
 SPCCS : silver plated copper clad steel

① High frequency connections.

② High frequency connections operating at high temperature. By their small dimensions, they are mainly designed for miniaturized connections, operating at high or low temperature.

## 75 Ω KX & RG coaxial cables

Oper. temperature Min/Max	Fire properties	Max. op. frequency GHz	Nominal capacitance pF/m	Attenuation (db/100 m)				Dielectric strength kV	Powers at 40°C (kw)				Velocity of propagation	Conti-nuous working voltage
				200 MHz	400 MHz	3000 MHz	10000 MHz		200 MHz	400 MHz	3000 MHz	10000 MHz		
-40 +85	NF C 32070/C2 IEC 60332 – 1&2	1	72.2	16	23	73		7	0.17	0.12	0.042		65.9	1700
-40 +85	NF C 32070/C2 IEC 60332 – 1&2	3	67.0	16	23	73		4.2	0.17	0.12	0.042		65.9	1700
-40 +85	NF C 32070/C2 IEC 60332 – 1&2	1	72.2	9.5	13	45		10	0.42	0.3	0.095		65.9	3700
-40 +85	NF C 32070/C2 IEC 60332 – 1&2	3	72.2	9.5	13	45		10	0.42	0.3	0.095		65.9	3700
-40 +85	NF C 32070/C2 IEC 60332 – 1&2	3	67.0	9.5	13	45		8	0.42	0.3	0.095		65.9	3700
-90 +200	NF C 32070/C1&C2 IEC 60332 – 1	3	75.5	40	56	160		2	0.17	0.11	0.032		69.5	900
-90 +230	NF C 32070/C1&C2 IEC 60332 – 1	3	72.2	40	56	160		2	0.17	0.11	0.032		69.5	900

## 93-95 Ω KX & RG coaxial cables

Oper. temperature Min/Max	Fire properties	Max. op. frequency GHz	Nominal capacitance pF/m	Attenuation (db/100 m)				Dielectric strength kV	Powers at 40°C (kw)				Velocity of propagation	Conti-nuous working voltage
				200 MHz	400 MHz	3000 MHz	10000 MHz		200 MHz	400 MHz	3000 MHz	10000 MHz		
-40 +85	NF C 32070/C2 IEC 60332 – 1&2	1	47.6	14	22	100		3					83.0	750
-90 +200	NF C 32070/C1&C2 IEC 60332 – 1	3	50.5	30	43	120		2	0.35	0.25	0.08		69.5	900
-90 +230	NF C 32070/C1&C2 IEC 60332 – 1	3	50.5	30	43	120		2	0.35	0.25	0.08		69.5	900

## Other standard cables

Impedance	Max. op. temp.	Dielectric	References according to		Nexans ref.	Conductor			Dielectric Ø mm	Braids		Sheath		Av. weight kg/km
			NF C 93-550	MIL C17		Composition n x Ø mm	Nature	Ø mm		Nb	Nature	Nature	Overall Ø mm	

### CABLES with 2 CONDUCTORS

<b>78 Ω</b>	<b>85°C</b>	<b>PE</b>		<b>RG 108 AU</b>	087061	7 x 0.32	TPC	0.96	2.0	1	TPC	PVC	6.0 ± 0.25	52
<b>95 Ω</b>	<b>85°C</b>	<b>PE</b>		<b>RG 22 BU</b>	087043	7 x 0.38	TPC	1.14	2.3	2	TPC	PVC	10.7 ± 0.25	181

TPC : tin plated copper

Reference	Oper. temperature Min / Max	Fire properties	Max. op. frequency GHz	Nominal capacitance pF/m	Attenuation (db/100 m)				Dielectric strength kV	Velocity of propagation	Continuous working voltage
					1 MHz	10 MHz	200 MHz	400 MHz			

<b>RG 108 AU</b>	-40 +85	NF C 32070/C2 IEC 60332 – 1&2	1	64.8		10	60	95	2	65.9	750
<b>RG 22 BU</b>	-40 +85	NF C 32070/C1 IEC 60332 – 1		53.2		5	20	29	2		

Application: High frequency connections.

These twinaxial cables are mainly designed for digital data transmissions in electronic systems.

# HALOGEN FREE COAXIAL CABLES

FLAMEX KX/RG

## Applications

Nexans produces a range of halogen free coaxial cables for data transmission and video signal in on-board equipments.

## 50 Ω and 75 Ω coaxial cables

## Construction

### 1- Conductor

Stranded or solid, in bare copper (BC), tin plated copper (TPC), silver plated copper (SPC) or copper clad steel (CCS)

### 2- Dielectric

PE

### 3- Screen

Single or double braid in bare, tinned or silvered copper

### 4- Sheath

Halogen free

Colour: black

Lay up with fire barrier tapes (in option).

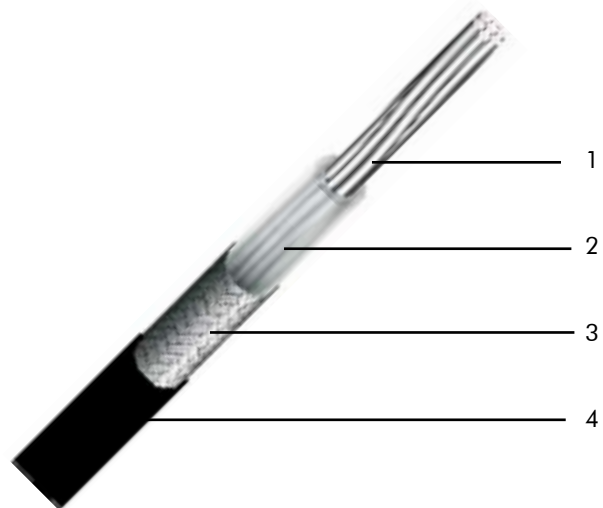

## Marking

«FILOTEX P FLAMEX RG XXX» (cable type) in white marking.

## Minimum bending radius







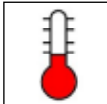
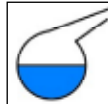

Static use : 5 x outer diameter

## Standards

Approved Bureau Veritas, MIL C 17 (RG) except attenuation values.

## Connectors

Compatible with standard connectors : SMA, SMB, TNC, BNC, N...

							
- 30°C to +80°C	Good chemical resistance (acids, oils, ...)	Flame and fire retardant (IEC 60332-1/2/3 cat. C)	Low smoke emission and low opacity (IEC 61034).	Non corrosive and non toxic (IEC 60754-2)	Flexible	EMI	Halogen free (IEC 60754-1)
							

## FLAMEX 50 Ω Halogen free coaxial cables

Nexans designation	Nexans reference	Conductor			Dielectric Ø mm	Braids		Sheath		Av. weight kg/km	Max. op. frequency GHz	Continuous working voltage
		Composition n x Ø mm	Nature	Ø mm		Nb	Nature	Nature	Overall Ø mm			
<b>FLAMEX KX 3B</b>	ET 299946	7x0.16	CCS	0.48	1.50 ± 0.10	1	TPC	FLAMEX	2.54 ± 0.13	10	3	1100
<b>FLAMEX RG 174</b>	ET 299956	7x0.16	CCS	0.48	1.52 ± 0.08	1	TPC	FLAMEX	2.79 ± 0.13	12.5	1	1100
<b>FLAMEX RG 58</b>	ET 299954	19x0.18	TPC	0.90	2.95 ± 0.10	1	TPC	FLAMEX	4.95 ± 0.10	41	3	1400
<b>FLAMEX RG 213</b>	ET 299957	7x0.75	BC	2.25	7.24 ± 0.18	1	BC	FLAMEX	10.30 ± 0.18	165	3	3700
<b>FLAMEX RG 214</b>	ET 299958	7x0.75	SPC	2.25	7.24 ± 0.18	2	SPC	FLAMEX	10.80 ± 0.18	198	11	3700

Capacitance : < 106 pF / m

Velocity of propagation : 65.9%

## FLAMEX 75 Ω Halogen free coaxial cables

Nexans designation	Nexans reference	Conductor			Dielectric Ø mm	Braids		Sheath		Av. weight kg/km	Max. op. frequency GHz	Continuous working voltage
		Composition n x Ø mm	Nature	Ø mm		Nb	Nature	Nature	Overall Ø mm			
<b>FLAMEX KX 6A</b>	ET 299952	7x0.20	BC	0.60	3.70 ± 0.12	1	BC	FLAMEX	6.10 ± 0.15	57	3	1700
<b>FLAMEX RG 59</b>	ET 299955	1x0.57	CCS	0.57	3.71 ± 0.10	1	BC	FLAMEX	6.15 ± 0.10	58	1	1700
<b>FLAMEX RG 11</b>	ET 299953	7x0.40	TPC	1.20	7.24 ± 0.18	1	BC	FLAMEX	10.30 ± 0.18	146	1	3700
<b>FLAMEX KX 8</b>	ET 299951	7x0.40	BC	1.20	7.25 ± 0.15	1	BC	FLAMEX	10.30 ± 0.20	145	3	3700
<b>FLAMEX RG 216</b>	ET 299965	7x0.40	TPC	1.20	7.24 ± 0.18	2	BC	FLAMEX	10.80 ± 0.18	185	3	3700

Capacitance : < 72.2 pF / m

Velocity of propagation : 65.9%

BC: bare copper, TPC: tin plated copper, SPC : silver plated copper, CCS: copper clad steel

## Attenuation values

	Designation	Nexans ref.	Attenuation at x MHz in db/100m (nominal values)						
			50	100	200	400	1000	3000	11000
			<b>50 Ω</b>	<b>FLAMEX KX 3B</b>	ET 299946			45	
	<b>FLAMEX RG174</b>	ET 299956	21.32	32.8		82.02	147.63		
	<b>FLAMEX RG58</b>	ET 299954	13.12	21.32		55.77	91.86		
	<b>FLAMEX RG213</b>	ET 299957	3.93	7.54		15.74	29.52		
	<b>FLAMEX RG214</b>	ET 299958	5.57			22.3		91.86	196.85
<b>75 Ω</b>	<b>FLAMEX KX6A</b>	ET 299952			20				
	<b>FLAMEX RG59</b>	ET 299955				29.52	52.48		
	<b>FLAMEX RG 11</b>	ET 299953				17.06	30.84		
	<b>FLAMEX KX8</b>	ET 299951			12				
	<b>FLAMEX RG 216</b>	ET 299965				21.32	75.45		

# TELECOM COAXIAL CABLES

RG types

## Applications

These coaxial cables are mainly designed for high frequency interconnections in telecommunication equipments.

If a high shielding effectiveness is required, use the double braided cables.

## 50 $\Omega$ and 75 $\Omega$ coaxial cables

## Construction

### 1- CONDUCTOR

Stranded or solid, in copper clad steel (CCS) or silver plated copper covered steel (SPCCS)

### 2- DIELECTRIC

PE, FEP, PTFE.

### 3- SCREEN

Single or double braid in bare copper or silver plated copper

### 4- SHEATH

PVC, FEP or halogen free

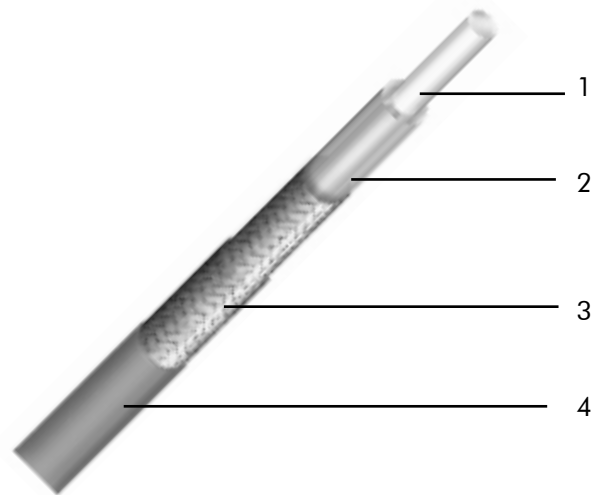

## Physical properties

Very good resistance to solvents (except halogen free versions)

Very good resistance to soldering operations

For halogen free versions (LSZH):

- pH > 4 and conductivity < 100mS/cm according to IEC 60754-1
- VW-1 and FT-1 according to UL and CSA standards
- Low smoke emissions according to IEC 61034-2

## Standards

NEXANS specification

## Connectors

Compatible with all standard connectors intended for RG cables

## Minimum bending radius

Static use : 5 x outer diameter

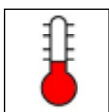

See on the following page



See on the following page



Flexible

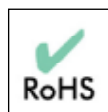

## 50 Ω telecom coaxial cables

Max. op. temp.	Dielectric	Nexans designation	Nexans reference	Conductor			Dielectric Ø mm	Braids		Sheath		Av. weight kg/km
				Composition n x Ø mm	Nature	Ø mm		Nb	Nature	Nature	Overall Ø mm	
80°C	Polyolefin	<b>RG 316 ST LSZH</b>	2PB272	7 x 0.17	SPCCS	0.51	1.52	1	SPC	Zero HAL	2.50 ± 0.10	10.8
		<b>RG 316 DT LSZH</b>	2PB273	7 x 0.17	SPCCS	0.51	1.52	2	SPC	Zero HAL	2.94 ± 0.15	18.2
		<b>RG 142 DT LSZH</b>	2PB274	1 x 0.95	SPCCS	0.95	2.95	2	SPC	Zero HAL	4.95 ± 0.13	45.6
180°C	FEP	<b>RG 316 ST FEP</b>	296891	7 x 0.17	SPCCS	0.5	1.50	1	SPC	FEP	2.50 ± 0.10	13.8
		<b>RG 316 DT FEP</b>	296892	7 x 0.17	SPCCS	0.5	1.50	2	SPC	FEP	2.90 ± 0.10	19.8
200°C	PTFE	<b>RG 178 ST PTFE</b>	111336	7 x 0.10	SPCCS	0.30	0.84	1	SPC	FEP	1.80 ± 0.10	8.3
		<b>RG 316 ST PTFE</b>	124467	7 x 0.17	SPCCS	0.5	1.50	1	SPC	FEP	2.50 ± 0.10	12.0
		<b>RG 316 DT PTFE</b>	124376	7 x 0.17	SPCCS	0.5	1.50	2	SPC	FEP	2.90 ± 0.10	19.6
		<b>RG 142 DT PTFE</b>	124380	1 x 0.95	SPCCS	0.95	2.95	2	SPC	FEP	4.95 ± 0.13	66.1

## 75 Ω telecom coaxial cables

Max. op. temp.	Dielectric	Nexans designation	Nexans reference	Conductor			Dielectric Ø mm	Braids		Sheath		Av. weight kg/km
				Composition n x Ø mm	Nature	Ø mm		Nb	Nature	Nature	Overall Ø mm	
80°C	Polyolefin	<b>RG 179 ST LSZH</b>	2PB270	7 x 0.10	SPCCS	0.30	1.60	1	SPC	Zero HAL	2.54 ± 0.13	12.3
		<b>RG 179 DT LSZH</b>	2PB271	7 x 0.10	SPCCS	0.30	1.60	2	SPC	Zero HAL	3.00 ± 0.15	15.8
	PE	<b>RG 179 ST PE/PVC</b>	288108	1 x 0.25	CCS	0.25	1.50 ± 0.10	1	BC	PVC	2.80 ± 0.12	12.6
		<b>RG 179 DT PE/PVC</b>	2PB389	1 x 0.25	CCS	0.25	1.50 ± 0.10	2	BC	PVC	3.20 ± 0.15	22.2
180°C	FEP	<b>RG 179 ST FEP</b>	296469	7 x 0.10	SPCCS	0.30	1.60	1	SPC	FEP	2.54 ± 0.13	15.7
		<b>RG 179 DT FEP</b>	2PA030	7 x 0.10	SPCCS	0.30	1.60	2	SPC	FEP	3.07 ± 0.10	25.3
200°C	PTFE	<b>RG 179 ST PTFE</b>	125480	7 x 0.10	SPCCS	0.30	1.60	1	SPC	FEP	2.54 ± 0.13	15.8
		<b>RG 179 DT PTFE</b>	124431	7 x 0.10	SPCCS	0.30	1.60	2	SPC	FEP	3.07 ± 0.10	22.6

BC: bare copper, TPC: tin plated copper, SPC: silver plated copper, CCS: copper clad steel, SPCCS: silver plated copper covered steel

## 50 $\Omega$ telecom coaxial cables

Oper. temperature Min / Max	Fire properties	Max. op. frequency GHz	Nominal capacitance pF/m	Attenuation (db/100 m)						Velocity of propagation	Continuous working voltage
				10 MHz	100 MHz	1000 MHz	900 MHz	1800 MHz	3000 MHz		
-25 +80	NF C 32070/C1 IEC 60332 – 1	3	95				86	120	160	70	900
-25 +80	NF C 32070/C1 IEC 60332 – 1	3	95				86	120	160	70	900
-25 +80	NF C 32070/C1 IEC 60332 – 1	3	95				43	62	82	70	1500
-90 +180	NF C 32070/C1&C2 IEC 60332 – 1	3	95				80	120		69.5	900
-90 +180	NF C 32070/C1&C2 IEC 60332 – 1	3	95				80	120		69.5	900
-90 +200	NF C 32070/C1&C2 IEC 60332 – 1	3	95				150	240		69.5	750
-90 +200	NF C 32070/C1&C2 IEC 60332 – 1	3	95				80	120		69.5	900
-90 +200	NF C 32070/C1&C2 IEC 60332 – 1	3	95				80	120		69.5	900
-90 +200	NF C 32070/C1&C2 IEC 60332 – 1	3	95				40	60		69.5	1400

## 75 $\Omega$ telecom coaxial cables

Oper. temperature Min / Max	Fire properties	Max. op. frequency GHz	Nominal capacitance pF/m	Attenuation (db/100 m)						Velocity of propagation	Continuous working voltage
				10 MHz	100 MHz	1000 MHz	900 MHz	1800 MHz	3000 MHz		
-25 +80	NF C 32070/C1 IEC 60332 – 1	3	64				100	140	185	70	900
-25 +80	NF C 32070/C1 IEC 60332 – 1	3	64				100	140	185	70	900
-20 +80	NF C 32070/C1 IEC 60332 – 1	3	67	8.5	28	89				66	900
-20 +80	NF C 32070/C1 IEC 60332 – 1	3	67	8.5	28	89				66	900
-90 +180	NF C 32070/C1&C2 IEC 60332 – 1	3	64				80	120		69.5	900
-90 +180	NF C 32070/C1&C2 IEC 60332 – 1	3	64				90	140		69.5	900
-90 +200	NF C 32070/C1&C2 IEC 60332 – 1	3	64				80	120		69.5	900
-90 +200	NF C 32070/C1&C2 IEC 60332 – 1	3	64				80	120		69.5	900



# LOW NOISE COAXIAL CABLES

CAS 85-22P  
CAS 250-20 P  
CAS 250-20 SP  
CAS 250-22

## Applications

Cables designed for low frequency connections submitted to displacements and vibrations during their operation.

250/600 Volts RMS

## Construction

### 1- CONDUCTOR

Stranded or solid in silver plated copper covered steel (SPCCS)

### 2- DIELECTRIC

PE or PTFE

### 3- ANTIMICROPHONIC NOISE COATING

### 4- SCREEN

Single braid in bare copper or silver plated copper

### 5- SHEATH

PVC or PTFE tape(s)

Colour: green for standard version.

Other colours on request.

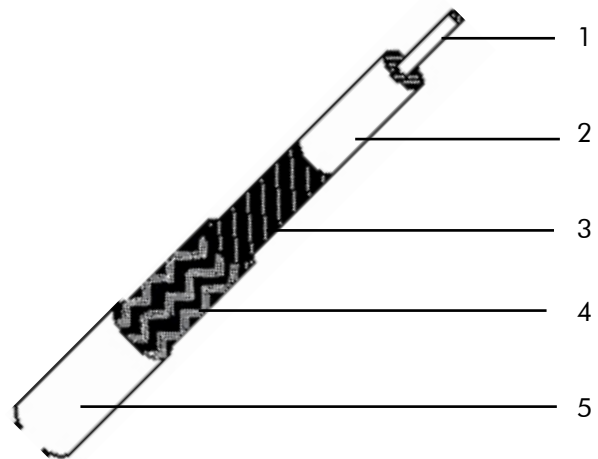

## Bending radius

Static use : 10 x outer diameter

## Standards

NEXANS specification

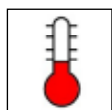

Up to +200°C



Flexible



RoHS

## Low noise coaxial cables

Dielectric	Designation	Nexans reference	Conductor			Dielectric Ø mm	Braids		Sheath	
			Composition n x Ø mm	Nature	Ø mm		Nb	Nature	Nature	Overall Ø mm
PE	<b>CAS 85-22P</b>	87067	1 x 0.30	SPCCS	0.30	1.10 ± 0.05	1	BC	PVC	2.15 ± 0.05
PTFE	<b>CAS 250-20 P</b>	87208	1 x 0.30	SPCCS	0.30	1.05 ± 0.05	1	SPC	PTFE	1.90 ± 0.10
PTFE	<b>CAS 250-20 SP</b>	87209	7 x 0.10	SPCCS	0.30	1.05 ± 0.05	1	SPC	PTFE	1.90 ± 0.10
PTFE	<b>CAS 250-22</b>	87068	1 x 0.30	SPCCS	0.30	0.98 ± 0.05	1	SPC	PTFE	2.15 ± 0.05

Designation	Nexans reference	Average weight kg/km	Nominal capacitance pF/m	Velocity of propagation	Continuous working voltage	Triboelectric low noise level
<b>CAS 85-22P</b>	87067	8.0	95	70	600	<200 µvolts
<b>CAS 250-20 P</b>	87208	8.9	90	76	600	<200 µvolts
<b>CAS 250-20 SP</b>	87209	8.8	90	76	600	<200 µvolts
<b>CAS 250-22</b>	87068	11.6	90	76	250	<200 µvolts

# MINIATURE COAXIAL CABLES

50 VMTX  
75 VMTX

## Applications

Miniaturized coaxial cables for high frequency transmissions.

## 50 $\Omega$ and 75 $\Omega$ coaxial cables

## Construction

### 1- CONDUCTOR

Solid in silver plated copper covered steel (SPCCS)

### 2- DIELECTRIC

Extruded PTFE

### 3- SCREEN

Single braid in silver plated copper

### 4- SHEATH

FEP

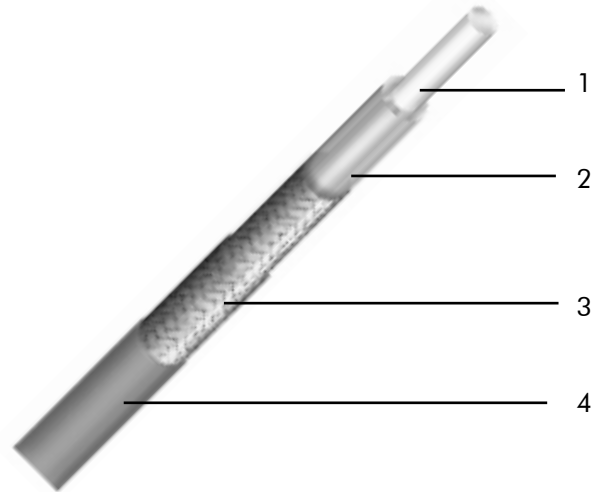

## Physical properties

Very good resistance to solvents  
Very good resistance to soldering operations

## Standards

NEXANS specification

## Bending radius

Static use : 10 x outer diameter

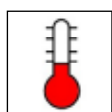

-90 to +200°C



Flexible



EMI



RoHS

## Miniature coaxial cables

Impedance	Dielectric	Designation	Nexans reference	Conductor			Dielectric Ø mm	Braids		Sheath	
				Composition n x Ø mm	Nature	Ø mm		Nb	Nature	Nature	Overall Ø mm
<b>50 Ω</b>	<b>PTFE</b>	<b>50 VMTX</b>	<b>87059</b>	1 x 0.17	SPCCS	0.17	0.52 ± 0.03	1	SPC	FEP	1.17 ± 0.05
<b>75 Ω</b>	<b>PTFE</b>	<b>75 VMTX</b>	<b>87060</b>	1 x 0.10	SPCCS	0.10	0.57 ± 0.05	1	SPC	FEP	1.22 ± 0.05

Designation	Nexans reference	Average weight kg/km	Max. op. frequency GHz	Nominal capacitance pF/m	Attenuation (db/100 m)						Velocity of propagation	Continuous working voltage
					10 MHz	100 MHz	400 MHz	1000 MHz	2000 MHz	3000 MHz		
<b>50 VMTX</b>	<b>87059</b>	3	3	85	22	54	115	220	320	450	69.5	250
<b>75 VMTX</b>	<b>87060</b>	3	3	60	36	70		220	320	390	69.5	250

# HAND FORMABLE COAXIAL CABLES

Quickform® 86 and 141

## Applications

Quickform® coaxial cables are specially recommended for high frequency connections (mobile phone equipment, radio beams, radar...).

Quickform® could be listed Style UL1354 if requested.

The Quickform® 86 is a substitute to M17/133-RG405.

The Quickform® 141 is a substitute to M17/133-RG402.

The special outer conductor allows to change the shape of the assembly; nevertheless, they are intended for static use.

50 Ω coaxial cables

## Construction

### 1- CONDUCTOR

Silver plated copper clad steel

### 2- DIELECTRIC

PTFE

### 3- OUTER CONDUCTOR

Tin soaked braid



## Properties

Quickform® coaxial cables have electrical performances close to those of semi-rigid cables (very low attenuation very high screening effectiveness) but with easy and economical processing :

- no need for drawing of the assembly,
- manual shaping with or without pattern,
- no previous stabilisation,
- fast connection with all types of connectors intended for standard semi-rigid cables.

## Standards

NEXANS specification  
IEC 61196-1  
IEC 61196-2

## Minimum bending radius

Static use: 7 mm (Quickform® 86), 11 mm (Quickform® 141)

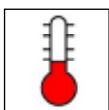

-65 to +150°C



Flame retardant  
(IEC 60332-1)



Flexible



EMI



RoHS

## Hand formable coaxial cables

Impedance	Dielectric	Designation	Nexans reference	Conductor			Dielectric Ø mm	Outer Conductor		Av. weight kg/km
				Composition n x Ø mm	Nature	Ø mm		Nature	Overall Ø mm	
<b>50 Ω</b>	<b>PTFE</b>	<b>QF86 Cw PTFE</b>	<b>296380</b>	1 x 0.51	SPCCS	0.51	1.60	Tin soaked braid	2.11	16.5
		<b>QF141 Cw PTFE</b>	<b>296379</b>	1 x 0.92	SPCCS	0.92	2.98	Tin soaked braid	3.50	43.8

Nexans reference	Maximum operating frequency GHz	Capacitance (pF/m)	Relative velocity of propagation (%)	Nominal attenuation (dB/m) at									
				0.1 GHz	0.3 GHz	1 GHz	2 GHz	3 GHz	5 GHz	10 GHz	15 GHz	20 GHz	26 GHz
<b>296380</b>	26	97	70	0.22	0.39	0.74	1.08	1.37	1.83	2.71	3.43	4.10	4.80
<b>296379</b>	26	97	70	0.12	0.21	0.42	0.64	0.82	1.12	1.70	2.22	2.61	3.13

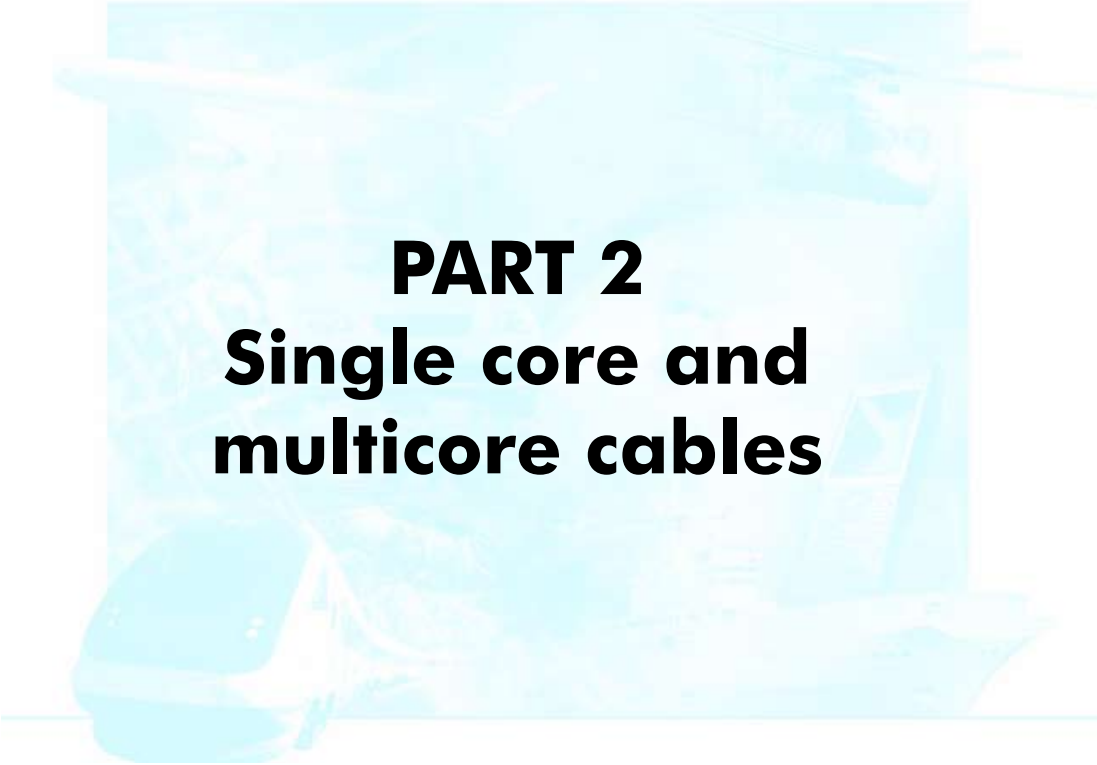

**PART 2**  
**Single core and multicore cables**



**80°C**

### Applications

These wires are designed for flexible connections submitted to a very high voltage.

4 000 Volts up to 12 000 Volts RMS

### Construction

#### 1 - CONDUCTOR

Stranded annealed tinned copper wires

#### 2 - INSULATION

Polyethylene

#### 3 - OUTER JACKET

Polyvinyl chloride(PVC)

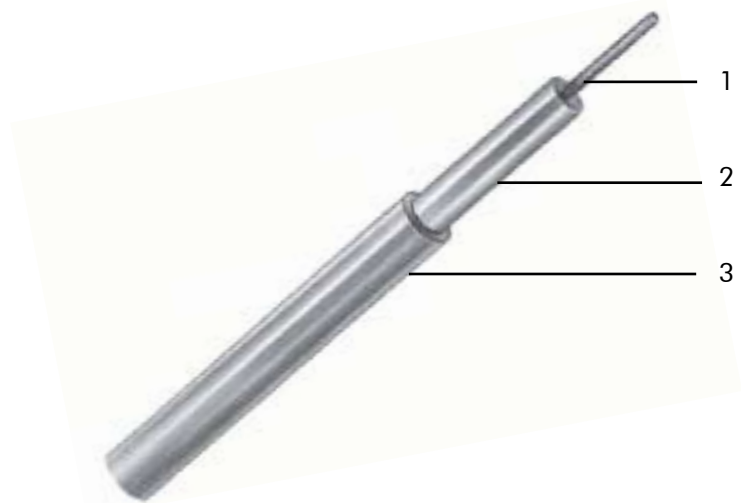

### Standards

NEXANS specification

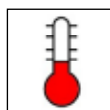

- 20°C to +80°C



Flame retardant  
(NF C 32-070/C2)



Flexible



RoHS

## HT - High voltage hook-up wires

Nexans Reference	Conductor			Nom. Ø over insulation mm	Overall Ø mm	Average weight Kg/km	Electrical Characteristics	
	Gauge AWG	Cross section mm <sup>2</sup>	Construction n x Ø mm				Operating voltage V.RMS	Test voltage V.CA
<b>HT 306 E</b>	20	0.60	19 X 0.20	2.3	3.1 ± 0.2	14	4000	7000
<b>HT 406 E</b>	20	0.60	19 X 0.20	3.0	4.2 ± 0.2	20	5000	10000
<b>HT 610 E</b>	16	1.34	19 X 0.30	4.5	6.2 ± 0.3	44	7000	12000
<b>HT 810 E</b>	16	1.34	19 X 0.30	6.0	8.2 ± 0.3	72	12000	20000

# UL 1007

## Hook-up wires

### Applications

Those wires are mainly designed for internal wiring in electrical and electronic equipments. They are well suited to work under stringent conditions. They are both UL and RoHS qualified. They can be used in all equipments in Europe or worldwide.

300 volts

### Construction

#### 1 - AME

Stranded tinned copper wires

#### 2 - ISOLATION

Polyvinyl chloride (PVC-UL)



### Standards

UL AWM Style 1007

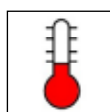

-40 °C to +80°C



Flame retardant  
UL VW-1



Flexible



RoHS

## ■ UL 1007 - Hook-up wires

Nexans Reference	Conductor			Overall diameter mm
	Gauge AWG	Cross section mm <sup>2</sup>	Construction n x Ø mm	
<b>UL 1007 300V 80 °C</b>	28	0.09	7 x 0.13	1.20 ± 0.05
<b>UL 1007 300V 80 °C</b>	26	0.14	7 x 0.16	1.30 ± 0.05
<b>UL 1007 300V 80 °C</b>	24	0.25	19 x 0.13	1.45 ± 0.05
<b>UL 1007 300V 80 °C</b>	22	0.38	19 x 0.16	1.60 ± 0.10
<b>UL 1007 300V 80 °C</b>	20	0.6	19 x 0.20	1.80 ± 0.10
<b>UL 1007 300V 80 °C</b>	18	0.93	19 x 0.25	2.20 ± 0.10
<b>UL 1007 300V 80 °C</b>	16	1.3	19 x 0.30	2.35 ± 0.10

## FM & FMA

### Screened and jacketed hook-up wires and multicore cables for low frequency applications

#### Applications

These flexible cables are specially designed for equipment wiring requiring a good efficient screen. For a reduced overall diameter, use FMA range.

Some typical applications:

- outdoor and indoor audio installations,
- microphone connections,
- wiring in equipment requiring efficient shielding against low frequency interference and inductive coupling.

**250 volts for AWG 24 gauges**  
**750 volts for AWG 22 gauges**

#### Construction

##### 1 - CONDUCTOR

Stranded tinned copper wires

##### 2 - INSULATION

Polyethylene (Pe) or polyvinyl chloride (PVC) according to the products

##### 3- SCREEN

Tinned copper braid

##### 4- OUTER JACKET

Flexible polyvinyl chloride (PVC)

NOTA: the items with the FILOTEX reference ending by «PS» only have a PVC sheath as filler between cores and screen.

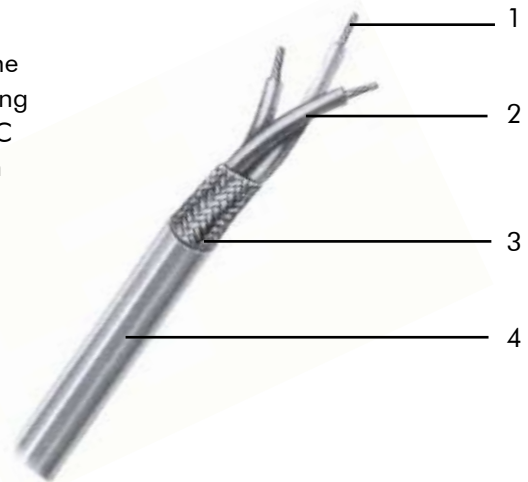

#### Standards

NEXANS specification

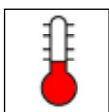

- 20°C to +80°C



Flame retardant  
(NF C 32-070/C2)



Flexible



## FM & FMA - Screened and jacketed hook-up wires and multicore cables

Nb. of cores	Nexans Reference	Base CoreORE				Overall diameter		Average weight Kg / Km	Colour coding of cores
		Conductor			Nom. Ø core mm	mini.	maxi.		
		Gauge AWG	Cross section mm <sup>2</sup>	Construction n x Ø mm		mm			
1	<b>FM 1 R</b>	24	0.22	7 x 0.20	1.2	2.3	2.7	10	White
	<b>FMA 1 R</b>	24	0.22	7 x 0.20	1.1	2.1	2.5	10	White
	<b>FM 1 M</b>	24	0.22	7 x 0.20	1.6	3.3	3.7	18	White
	<b>FMA 1 M</b>	24	0.22	7 x 0.20	1.5	2.6	3.0	13	White
	<b>FM 1</b>	22	0.38	12 x 0.20	2.5	4.7	5.3	35	White
	<b>FMA 1</b>	22	0.34	7 x 0.25	2.0	3.2	3.6	19	White
	<b>FM 1 P</b>	22	0.38	12 x 0.20	2.5	4.7	5.3	34	Natural
	<b>FMA 1 P</b>	22	0.34	7 x 0.25	2.0	3.2	3.6	18	Natural
2	<b>FM 2 R</b>	24	0.22	7 x 0.20	1.2	3.8	4.2	24	White, Blue
	<b>FMA 2 R</b>	24	0.22	7 x 0.20	1.1	3.5	3.9	19	White, Blue
	<b>FM 2 M</b>	24	0.22	7 x 0.20	1.5	4.7	5.3	34	White, Yellow
	<b>FMA 2 M</b>	24	0.22	7 x 0.20	1.5	4.4	4.8	26	White, Yellow
	<b>FM 2</b>	22	0.38	12 x 0.20	2.0	5.7	6.3	49	White, Blue
	<b>FMA2</b>	22	0.34	7 x 0.25	2.0	5.3	5.9	39	White, Blue
	<b>FM 2 P</b>	22	0.38	12 x 0.20	2.0	5.7	6.3	45	Natural, Red
	<b>FMA 2 P</b>	22	0.34	7 x 0.25	2.0	5.3	5.9	34	Natural, Red
	<b>FM 2 PS</b>	22	0.31	40 x 0.10	2.2	7.7	8.3	90	White, Yellow
<b>FMA 2 PS</b>	22	0.34	7 x 0.25	2.0	6.8	7.4	72	White, Yellow	
3	<b>FM 3 R</b>	24	0.22	7 x 0.20	1.2	4.0	4.4	27	White, Blue, Red
	<b>FMA 3 R</b>	24	0.22	7 x 0.20	1.1	3.7	4.1	18	White, Blue, Red
	<b>FM 3</b>	22	0.38	12 x 0.20	2.0	5.7	6.3	49	White, Blue, Red
	<b>FMA3</b>	22	0.34	7 x 0.25	2.0	5.6	6.2	32	White, Blue, Red
	<b>FM 3 PS</b>	22	0.31	40 x 0.10	2.2	7.8	8.6	90	White, Yellow, Green
	<b>FMA 3 PS</b>	22	0.34	7 x 0.25	2.0	7.1	7.7	79	White, Yellow, Green
4	<b>FM 4 R</b>	24	0.22	7 x 0.20	1.2	5.0	5.4	40	White, Blue, Red, Yellow
	<b>FMA 4 R</b>	24	0.22	7 x 0.20	1.1	4.0	4.4	19	White, Blue, Red, Yellow
	<b>FM 4</b>	22	0.38	12 x 0.20	2.0	6.7	7.3	71	White, Blue, Red, Yellow
	<b>FMA 4</b>	22	0.34	7 x 0.25	2.0	6.3	6.9	23	White, Blue, Red, Yellow
	<b>FM 4 PS</b>	22	0.31	40 x 0.10	2.2	8.1	8.9	104	White, Yellow, Green, Blue
	<b>FMA 4 PS</b>	22	0.34	7 x 0.25	2.0	7.7	8.3	91	White, Yellow, Green, Blue
5	<b>FM 5 R</b>	24	0.22	7 x 0.20	1.2	5.6	6.0	48	White, Blue, Red, Yellow, Green
	<b>FMA 5 R</b>	24	0.22	7 x 0.20	1.1	4.4	4.8	25	White, Blue, Red, Yellow, Green
	<b>FM 5</b>	22	0.38	12 x 0.20	2.0	7.7	8.3	92	White, Blue, Red, Yellow, Green
	<b>FMA 5</b>	22	0.34	7 x 0.25	2.0	7.1	7.7	47	White, Blue, Red, Yellow, Green
6	<b>FM 6 R</b>	24	0.22	7 x 0.20	1.1	5.0	5.6	42	White, Blue, Red, Yellow, Green, Black
	<b>FMA 6 R</b>	24	0.22	7 x 0.20	1.1	4.7	5.1	24	White, Blue, Red, Yellow, Green, Black
	<b>FM 6</b>	22	0.38	12 x 0.20	2.0	8.3	9.1	54	White, Blue, Red, Yellow, Green, Black
	<b>FMA 6</b>	22	0.34	7 x 0.25	2.0	7.7	8.5	52	White, Blue, Red, Yellow, Green, Black

The cables with the letter «P» in the reference (example FMA 2P) have the polyethylene insulated cores, the other cables have the PVC insulated cores.

# EHE & EHEA

## Screened and jacketed hook-up wires and multicore cables for low frequency

### Applications

These flexible cables are mainly designed for use in applications requiring high efficiency screening at low frequencies. The screen is made up of a continuous high conductive thermoplastic sheath and provides a shielding efficiency inversely proportional to the frequency.

So a very high efficiency is obtained at industrial frequencies. For a reduced overall diameter, use EHEA range. Easy stripping, as well as grounding, because of the drain wire placed under the thermoplastic sheath.

### 250 Volts and 750 Volts according to the products

### Construction

#### 1 - CONDUCTOR

Stranded tinned copper wires

#### 2 - INSULATION

Polyethylene (Pe)

#### 3- DRAIN WIRE

#### 4- SCREEN

High conductive sheath

#### 5- OUTER JACKET

Flexible polyvinyl chloride (PVC)

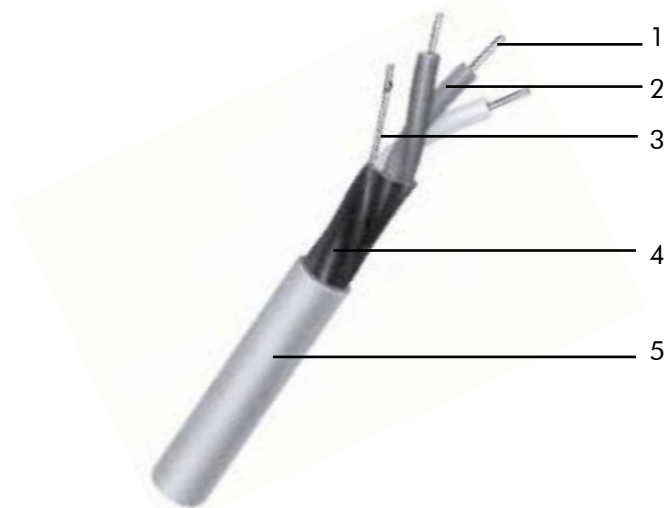

Single core and multicore cables

### Standards

NEXANS specification

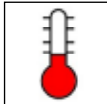
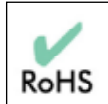
				
<p>- 20°C to +80°C</p>	<p>Flame retardant (NF C 32-070/C2)</p>	<p>Flexible</p>	<p>EMI</p>	<p>RoHS</p>

## EHE & EHEA - Screened and jacketed hook-up wires and multicore cables

Nb. of cores.	Nexans Reference	Base Core				Overall Ø mm		Average weight Kg / Km	Operating voltage	Colour coding of cores
		Conductor			Nominal Ø core mm	Mini.	Maxi.			
		Gauge AWG	Cross section mm <sup>2</sup>	Construction n x Ø mm						
1	<b>EHEA 1 PR</b>	24	0.22	7 x 0.20	1.1	2.4	2.8	8	250 V	Natural
	<b>EHEA 1 P</b>	22	0.34	7 x 0.25	2.0	3.4	3.8	14	750 V	Natural
2	<b>EHE 2 PR</b>	24	0.22	7 x 0.20	1.2	3.8	4.2	12	250 V	Natural, Blue
	<b>EHEA 2 PR</b>	24	0.22	7 x 0.20	1.1	3.5	3.9	14	250 V	Natural, Blue
	<b>EHE 2 P</b>	22	0.38	12 x 0.20	2.0	5.5	6.1	22	750 V	Natural, Blue
	<b>EHEA 2 P</b>	22	0.34	7 x 0.25	2.0	5.5	6.1	22	750 V	Natural, Blue
3	<b>EHE 3 PR</b>	24	0.22	7 x 0.20	1.2	4.0	4.4	14	250 V	Natural, Blue, Red
	<b>EHEA 3 PR</b>	24	0.22	7 x 0.20	1.1	3.8	4.2	13	250 V	Natural, Blue, Red
	<b>EHE 3 P</b>	22	0.38	12 x 0.20	2.0	6.4	7.0	31	750 V	Natural, Blue, Red
4	<b>EHE 4 PR</b>	24	0.22	7 x 0.20	1.2	4.6	5.0	16	250 V	Natural, Blue, Red, Yellow
	<b>EHEA 4 PR</b>	24	0.22	7 x 0.20	1.1	4.2	4.6	14	250 V	Natural, Blue, Red, Yellow
5	<b>EHEA 5 PR</b>	24	0.22	7 x 0.20	1.1	4.6	5.0	15	250 V	Natural, Blue, Red, Yellow, Green
6	<b>EHEA 6 PR</b>	24	0.22	7x 0.20	1.1	4.9	5.3	16	250 V	Natural, Blue, Red, Yellow, Green, Black

## SMA & SMBL

Unscreened and jacketed (SMA),  
screened and jacketed (SMBL)  
multicore cables

### Applications

Flexible cables designed for internal wiring in equipment, found in many markets (instrumentation, process-control, remote control, electronic industrial equipment,...)

500 Volts RMS

### Construction

#### 1- CONDUCTOR

Stranded tinned copper wires

#### 2- INSULATION

Flexible polyvinyl chloride (PVC)

#### 3- LAY UP

Polyester tape (for screened cables only)

#### 4- SCREEN

Tinned copper braid (for screened cables only)

#### 5- OUTER JACKET

Polyvinyl chloride (PVC)



### Colour coding

Colour coding of the cores by plain colours and rings.

### Standards

NEXANS specification

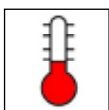

- 20°C to +80°C



Flame retardant  
(NF C 32-070/C2)



Flexible

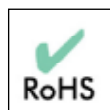

RoHS

## SMA - Unscreened and jacketed multicore cables

Nb. of cores	Nexans Reference	Cross section 0.22 mm <sup>2</sup> - AWG24			Cross section 0.34 mm <sup>2</sup> - AWG22			Cross section 0.60 mm <sup>2</sup> - AWG20		
		Ø	+/-	Average weight Kg/Km	Ø	+/-	Average weight Kg/Km	Ø	+/-	Average weight Kg/Km
		mm			mm			mm		
2	SMA 02x...	3.10	0.15	11.33	3.70	0.15	16.60	4.25	0.15	28.21
3	SMA 03x...	3.30	0.15	14.84	3.80	0.15	20.70	4.70	0.15	36.87
4	SMA 04x...	3.70	0.15	19.37	4.25	0.15	27.00	5.30	0.20	47.33
5	SMA 05x...	3.90	0.15	22.13	4.60	0.15	32.13	5.80	0.20	56.32
7	SMA 07x...	4.20	0.15	28.98	5.00	0.15	42.74	6.25	0.20	72.61
10	SMA 10x...	5.55	0.20	43.85	6.25	0.20	59.41	8.15	0.20	99.56
12	SMA 12x...	5.70	0.20	49.99	6.35	0.20	67.34	8.35	0.25	114.42
19	SMA 19x...	6.40	0.20	70.30	7.50	0.25	102.14	9.70	0.25	170.20
27	SMA 27x...	7.80	0.25	100.83	9.50	0.25	153.58	11.50	0.25	234.71
37	SMA 37x...	8.50	0.25	129.11	10.00	0.25	188.88	13.50	0.30	330.92

## SMBL - Screened and jacketed multicore cables

Nb. of cores	Nexans Reference	Cross section 0.22 mm <sup>2</sup> AWG24			Cross section 0.34 mm <sup>2</sup> AWG22			Cross section 0.60 mm <sup>2</sup> AWG20			Cross section 0.93 mm <sup>2</sup> AWG18			Cross section 1.34 mm <sup>2</sup> AWG16		
		Ø	+/-	Av. weight Kg/Km	Ø	+/-	Av. weight Kg/Km	Ø	+/-	Av. weight Kg/Km	Ø	+/-	Av. weight Kg/Km	Ø	+/-	Av. weight Kg/Km
		mm			mm			mm			mm			mm		
2	SMBL 02x...	3.60	0.15	19.89	4.40	0.15	25.41	5.10	0.20	34.69	5.75	0.20	46.63	6.30	0.20	57.47
3	SMBL03x...	3.80	0.15	23.81	4.55	0.15	30.96	5.40	0.20	45.83	6.00	0.20	65.11	6.65	0.20	76.39
4	SMBL 04x...	4.10	0.15	29.24	5.00	0.15	38.59	5.90	0.20	57.01	6.80	0.20	78.38	7.40	0.25	99.80
5	SMBL 05x...	4.40	0.15	32.40	5.65	0.20	49.38	6.50	0.20	68.84	7.30	0.25	93.45	8.20	0.25	121.82
7	SMBL 07x...	4.90	0.15	45.29	5.80	0.20	61.40	6.90	0.20	92.43	8.00	0.25	122.12	9.00	0.25	160.78
10	SMBL 10x...	6.00	0.15	57.49	7.25	0.25	81.94	8.90	0.25	126.59	10.20	0.30	174.41	11.60	0.30	230.88
12	SMBL12x...	6.10	0.20	63.33	7.30	0.25	91.28	8.90	0.25	141.95	10.30	0.30	194.36	11.70	0.30	258.8
19	SMBL19x...	7.05	0.25	90.77	8.50	0.25	131.16	10.55	0.30	205.2	12.10	0.30	287.34	14.30	0.30	409.74
27	SMBL 27x...	8.75	0.25	129.78	9.90	0.25	175.04	12.80	0.30	294.79	14.90	0.30	418.65	17.40	0.35	576.29
37	SMBL 37x...	9.45	0.25	160.87	11.10	0.30	229.01	14.30	0.30	384.18	16.40	0.35	539.74	19.50	0.40	759.42

## Description of the core

Conductor			Ø Insulation mm
Cross section mm <sup>2</sup>	Gauge AWG	Construction n x Ø mm	
0.22	24	7 x 0.20	1.04
0.34	22	7 x 0.25	1.24
0.60	20	19x 0.20	1.65
0.93	18	19 x 0.25	1.90
1.34	16	19 x 0.30	2.27

Example of ordering : SMA 7 x 0.34 ; SMBL 19 x 0.93

## SMA/SMBL colour coding

Core. n°	Plain colour	Core n°	Plain colour/ Ring colour	Core. n°	Plain colour	Core n°	Plain colour/ Ring colour
1	White	11	White/Blue	21	Blue/Brown	31	Yellow/Green
2	Light Blue	12	White/Yellow	22	Blue/Black	32	Yellow/Grey
3	Yellow	13	White/Brown	23	Blue/Red	33	Yellow/Orange
4	Brown	14	White/Black	24	Blue/Green	34	Yellow/Purple
5	Black	15	White/Red	25	Blue/Grey	35	Brown/Black
6	Red	16	White/Green	26	Blue/Orange	36	Brown/Red
7	Green	17	White/Grey	27	Blue/Purple	37	Brown/Green
8	Grey	18	White/Orange	28	Yellow/Brown		
9	Orange	19	White/Purple	29	Yellow/Black		
10	Purple	20	White/Yellow	30	Yellow/Red		

## GRTH & CCTB

Unscreened and jacketed (GRTH),  
screened and jacketed (CCTB)  
multicore cables

### Applications

Flexible cables designed for internal wiring in equipment, operating at a maximum voltage of 750 V RMS, found in many markets (instrumentation, process-control, remote control, electronic industrial equipment...),

750 Volts RMS

### Construction

#### 1 - CONDUCTOR

Stranded tinned copper wires

#### 2 - INSULATION

Flexible polyvinyl chloride (PVC)

#### 3- LAY UP

Polyester tape (for screened cables only)

#### 4- SCREEN

Tinned copper braid

#### 5- OUTER JACKET

Polyvinyl chloride (PVC)



### Colour coding

Colour coding of the cores by plain colours and rings.

### Standards

NEXANS specification

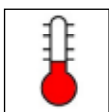

- 20°C to +80°C



Flame retardant  
(NF C 32-070/C2)



Flexible

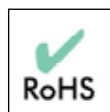

## GRTH - Unscreened and jacketed multicore cables

Nb. of cores	Nexans Reference	Cross section <b>0.34 mm<sup>2</sup></b> <b>AWG22</b>			Cross section <b>0.60 mm<sup>2</sup></b> <b>AWG20</b>			Cross section <b>0.93 mm<sup>2</sup></b> <b>AWG18</b>			Cross section <b>1.34 mm<sup>2</sup></b> <b>AWG16</b>			Cross section <b>1.91 mm<sup>2</sup></b> <b>AWG14</b>		
		Overall Ø		Average weight Kg/Km	Overall Ø		Average weight Kg/Km	Overall Ø		Average weight Kg/Km	Overall Ø		Average weight Kg/Km	Overall Ø		Average weight Kg/Km
		min.	max.		min.	max.		min.	max.		min.	max.		min.	max.	
		mm		mm		mm		mm		mm		mm		mm		
<b>2</b>	<b>GRTH 02x...</b>	5.0	5.4	34	5.2	5.6	41	6.7	7.1	64	7.0	7.5	75	7.2	7.7	86
<b>3</b>	<b>GRTH 03x...</b>	5.2	5.6	38	5.7	6.1	50	6.9	7.4	74	7.4	7.9	94	7.8	8.3	109
<b>4</b>	<b>GRTH 04x...</b>	5.8	6.2	47	6.3	6.7	62	7.8	8.3	95	8.3	8.8	116	8.5	9.0	135
<b>7</b>	<b>GRTH 07x...</b>	7.2	7.7	74	7.8	8.3	99	9.0	9.5	138	9.0	9.5	147	10.6	11.2	221

## CCTB - Screened and jacketed multicore cables

Nb. of cores	Nexans Reference	Cross section <b>0.60 mm<sup>2</sup></b> <b>AWG20</b>			Cross section <b>0.93 mm<sup>2</sup></b> <b>AWG18</b>			Cross section <b>1.34 mm<sup>2</sup></b> <b>AWG16</b>			Cross section <b>1.91 mm<sup>2</sup></b> <b>AWG14</b>		
		Overall Ø		Average weight Kg/Km	Overall Ø		Average weight Kg/Km	Overall Ø		Average weight Kg/Km	Overall Ø		Average weight Kg/Km
		min.	max.		min.	max.		min.	max.		min.	max.	
		mm		mm		mm		mm		mm		mm	
<b>2</b>	<b>CCTB 02x...</b>	6.0	6.4	57	6.9	7.4	64	7.3	7.8	90	8.0	8.5	113
<b>3</b>	<b>CCTB 03x...</b>	6.4	6.8	66	7.3	7.8	87	7.8	8.3	106	8.6	9.1	134
<b>4</b>	<b>CCTB 04x...</b>	7.2	7.7	83	7.8	8.3	103	8.6	9.1	127	9.4	9.9	163

## Description of the core

Conductor			Ø of core mm
Cross section mm <sup>2</sup>	Gauge AWG	Construction n x Ø mm	
0.34	22	7 x 0.25	2.15 ± 0.15
0.60	20	19 x 0.20	2.35 ± 0.15
0.93	18	19 x 0.25	2.65 ± 0.15
1.34	16	19 x 0.30	2.85 ± 0.15
1.91	14	27 x 0.30	3.20 ± 0.20

Example of ordering : GRTH 02 x 0.34 ; CCTB 4 x 0.93

## GRTH/CCTB colour coding

Cond. n°	Plain colour
1	Black
2	Light Blue
3	Brown*
4	Grey*
5	Orange*
6	Red*
7	Purple*

\* From 3 cores, the last one is Yellow/Green  
- Example for 3 conductors : Black – Light blue – Yellow/Green

# G250

**Flexible pairs  
Screened with overall braid**

## Applications

Interconnection cables for intercoms. Flexible links for low current and electronics use or where screening is required between circuits, mainly for data transmission.

**250 Volts**

## Construction

### 1- CORE

Stranded, 7x0.20 mm tinned copper

### 2- INSULATION

PVC

### 3- LAY UP

Under polyester tape

### 4- SCREEN

Tinned copper braid  
K>55%

### 5- OUTER JACKET

Very flexible PVC with a ripcord under the jacket.

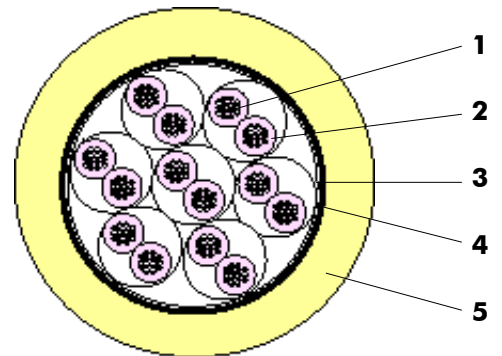

Single core and multicore cables

## Colour coding

Colour coding of the cores by plain colours and rings.

## Standards

NEXANS specification

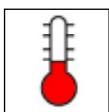

- 20°C to +80°C



Flame retardant  
(NF C 32-070/C2)



Flexible

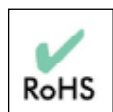

## G250 - Flexible pairs, screened with overall braid

Nb of pairs	Nexans Reference	Core			Braid		Overall diameter		Average weight Kg/Km
		Gauge AWG	Cross section mm <sup>2</sup>	Construction n x Ø mm	Ø strand	Ø mm	Ø mm	Tolerance mm	
2	<b>G250 2/2</b>	24	0.22	7 x 0.20	0.12	3.55	5.1	± 0.30	36
3	<b>G250 3/2</b>	24	0.22	7 x 0.20	0.12	4.00	5.50	± 0.40	44
5*	<b>G250 5/2</b>	24	0.22	7 x 0.20	0.12	5.1	6.6	± 0.40	64
7	<b>G250 7/2</b>	24	0.22	7 x 0.20	0.12	5.55	7.1	± 0.40	82
10	<b>G250 10/2</b>	24	0.22	7 x 0.20	0.13	6.60	8.1	± 0.40	106
12	<b>G250 12/2</b>	24	0.22	7 x 0.20	0.13	7.10	8.7	± 0.40	123
15	<b>G250 15/2</b>	24	0.22	7 x 0.20	0.13	7.95	9.6	± 0.50	147
21	<b>G250 21/2</b>	24	0.22	7 x 0.20	0.15	9.30	11.3	± 0.50	208
25	<b>G250 25/2</b>	24	0.22	7 x 0.20	0.15	10.40	12.7	± 0.40	242
30	<b>G250 30/2</b>	24	0.22	7 x 0.20	0.15	11.90	14.70	± 0.60	300

\* PVC filler

## Electrical characteristics

Attenuation	Value	Unit
Maximum loop resistance at 20°C	≤ 200	Ω/km
Insulation resistance at 20°C at 200 volts dc	≥ 500	MΩ.km

## G250 colour coding

PAIR #	1	2	3	4	5	6	7	8	9	10
<b>WIRE 1</b>	Blue	Yellow	Brown	Black	Green	White/Blue	Yellow/Blue	Brown/Blue	Blue/Black	Green/Blue
<b>WIRE 2</b>	White	White	White	White	White	White	White	White	White	White

PAIR #	11	12	13	14	15	16	17	18	19	20
<b>WIRE 1</b>	White/Yellow	Yellow/Brown	Yellow/Black	Yellow/Green	White/Brown	Brown/Black	Brown/Green	White/Black	Green/Black	White/Green
<b>WIRE 2</b>	White	White	White	White	White	White	White	White	White	White

PAIR #	21	22	23	24	25	26	27	28	29	30
<b>WIRE 1</b>	Blue	Yellow	Brown	Black	Green	White/Blue	Yellow/Blue	Brown/Blue	Blue/Black	Green/Blue
<b>WIRE 2</b>	White/Red	White/Red	White/Red	White/Red	White/Red	White/Red	White/Red	White/Red	White/Red	White/Red

White/Blue = White ring Blue

## SMA-ZH & SMLB-ZH

Unscreened and jacketed (SMA-ZH),  
screened and jacketed (SMLB-ZH)  
halogen free multicore cables

### Applications

Flexible cables designed for internal wiring in equipment, found in many markets (instrumentation, process-control, remote control, electronic industrial equipment,...) Halogen free, they are intended to be used in places where the protection of the people and equipment is vital.

We recommend to use them for cabinet wiring in public areas such as railway or subway stations but also in industrial areas, etc...

500 Volts RMS

### Construction

#### 1- CONDUCTOR

Stranded tinned copper wires

#### 2- INSULATION

Halogen free

#### 3- LAY UP

Polyester tape (for screened cables only)

#### 4- SCREEN

Tinned copper braid (for screened cables only)

#### 5- OUTER JACKET

Halogen free









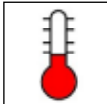

### Colour coding

Colour coding of the cores by plain colours and rings.

### Standards

NEXANS specification  
These cables are UL 21283 qualified (80°C). They can be manufactured with an UL marking on request.

							
- 40°C to +80°C	Flame retardant (NF C 32-070/C2, IEC 60332-1/2)	Low smoke emission and low opacity (IEC 61034)	Non corrosive and non toxic (IEC 60754-2)	Flexible	Screened versions	Halogen free (IEC 60754-1)	RoHS

## SMA-ZH - Unscreened and jacketed halogen free multicore cables

Nb. of cores	Nexans Reference	Cross section <b>0,22 mm<sup>2</sup></b> <b>(AWG24)</b>			Cross section <b>0,34 mm<sup>2</sup></b> <b>(AWG22)</b>			Cross section <b>0,60 mm<sup>2</sup></b> <b>(AWG20)</b>			Cross section <b>0,93 mm<sup>2</sup></b> <b>(AWG18)</b>		
		Ø	+/-	Av. weight Kg/Km	Ø	+/-	Av. weight Kg/Km	Ø	+/-	Av. weight Kg/Km	Ø	+/-	Av. weight Kg/Km
		mm			mm			mm			mm		
<b>2</b>	<b>SMA-ZH 02x...</b>	3.10	0.40	12	3.70	0.40	17	4.25	0.40	23	4.70	0.40	31
<b>3</b>	<b>SMA-ZH 03x...</b>	3.30	0.40	15	3.80	0.40	21	4.70	0.40	33	5.10	0.40	43
<b>4</b>	<b>SMA-ZH 04x...</b>	3.70	0.40	20	4.25	0.40	28	5.30	0.40	43	5.50	0.40	53
<b>5</b>	<b>SMA-ZH 05x...</b>	3.90	0.40	22	4.60	0.40	33	5.80	0.40	52	6.25	0.40	68
<b>7</b>	<b>SMA-ZH 07x...</b>	4.20	0.40	28	5.00	0.40	42	6.25	0.40	67	7.15	0.50	96
<b>12</b>	<b>SMA-ZH 12x...</b>	5.70	0.40	49	6.35	0.40	65	8.35	0.50	111	9.60	0.50	161
<b>19</b>	<b>SMA-ZH 19x...</b>	6.40	0.40	67	7.50	0.50	98	9.70	0.50	164	11.40	0.60	245
<b>27</b>	<b>SMA-ZH 27x...</b>	7.80	0.50	96	9.50	0.50	147	11.50	0.50	223	13.85	0.60	347
<b>37</b>	<b>SMA-ZH 37x...</b>	8.50	0.50	121	10.00	0.50	178	13.50	0.60	316	15.60	0.60	465

## SMBL-ZH - Screened and jacketed halogen free multicore cables

Nb. of cores	Nexans Reference	Cross section <b>0,22 mm<sup>2</sup></b> <b>AWG24</b>			Cross section <b>0,34 mm<sup>2</sup></b> <b>AWG22</b>			Cross section <b>0,60 mm<sup>2</sup></b> <b>AWG20</b>			Cross section <b>0,93 mm<sup>2</sup></b> <b>AWG18</b>		
		Ø	+/-	Av. weight Kg/Km	Ø	+/-	Av. weight Kg/Km	Ø	+/-	Av. weight Kg/Km	Ø	+/-	Av. weight Kg/Km
		mm			mm			mm			mm		
<b>2</b>	<b>SMBL-ZH 02x...</b>	3.60	0.40	20	4.40	0.40	27	5.10	0.40	36	5.75	0.40	49
<b>3</b>	<b>SMBL-ZH 03x...</b>	3.80	0.40	24	4.55	0.40	32	5.40	0.40	47	6.00	0.40	61
<b>4</b>	<b>SMBL-ZH 04x...</b>	4.10	0.40	28	5.00	0.40	40	5.90	0.40	58	6.80	0.40	80
<b>5</b>	<b>SMBL-ZH 05x...</b>	4.40	0.40	32	5.65	0.40	51	6.50	0.40	70	7.30	0.50	95
<b>7</b>	<b>SMBL-ZH 07x...</b>	4.90	0.40	42	5.80	0.40	59	6.90	0.40	87	8.00	0.50	122
<b>12</b>	<b>SMBL-ZH 12x...</b>	6.10	0.40	62	7.00	0.50	88	8.90	0.50	140	10.30	0.60	193
<b>19</b>	<b>SMBL-ZH 19x...</b>	6.90	0.40	90	8.50	0.50	130	10.55	0.60	200	12.10	0.60	283
<b>27</b>	<b>SMBL-ZH 27x...</b>	8.75	0.50	126	9.90	0.50	170	12.80	0.60	290	14.90	0.60	412
<b>37</b>	<b>SMBL-ZH 37x...</b>	9.25	0.50	155	11.10	0.60	222	14.30	0.60	375	16.40	0.70	530

## Description of the core

Conductor			Ø Insulation mm
Cross section mm <sup>2</sup>	Gauge AWG	Construction n x Ø mm	
0.22	24	7 x 0.20	1.04
0.34	22	7 x 0.25	1.24
0.60	20	19x 0.20	1.65
0.93	18	19 x 0.25	1.90

Example of ordering : SMA-ZH 7 x 0.34 ; SMBL-ZH 19 x 0.93

## SMA-ZH/SMBL-ZH colour coding

Core. n°	Plain colour	Core n°	Plain colour/ Ring colour	Core. n°	Plain colour	Core n°	Plain colour/ Ring colour
1	White	11	White/Blue	21	Blue/Brown	31	Yellow/Green
2	Light Blue	12	White/Yellow	22	Blue/Black	32	Yellow/Grey
3	Yellow	13	White/Brown	23	Blue/Red	33	Yellow/Orange
4	Brown	14	White/Black	24	Blue/Green	34	Yellow/Purple
5	Black	15	White/Red	25	Blue/Grey	35	Brown/Black
6	Red	16	White/Green	26	Blue/Orange	36	Brown/Red
7	Green	17	White/Grey	27	Blue/Purple	37	Brown/Green
8	Grey	18	White/Orange	28	Yellow/Brown		
9	Orange	19	White/Purple	29	Yellow/Black		
10	Purple	20	White/Yellow	30	Yellow/Red		

# G250-ZH

**Halogen free flexible pairs  
Screened with overall braid**

## Applications

Interconnection cables for intercoms. Flexible links for low current and electronics use or where screening is required between circuits, mainly for data transmission.

Halogen free, they are intended to be used in places where the protection of the people and equipment is vital.

We recommend to use them for cabinet wiring in public areas such as railway or subway stations but also in industrial areas, etc...

**250 Volts**

## Construction

### 1- CORE

Stranded, 7x0.20 mm tinned copper

### 2- INSULATION

Halogen free

### 3- LAY UP

Under polyester tape

### 4- SCREEN

Tinned copper braid

K>55%

### 5- OUTER JACKET

Halogen free

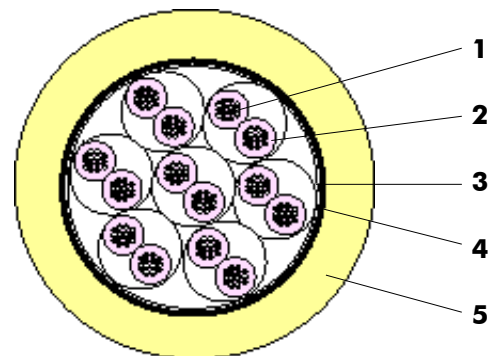

Single core and multicore cables







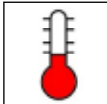

## Colour coding

Colour coding of the cores by plain colours and rings.

## Standards

NEXANS specification

These cables are UL 21283 qualified (80°C). They can be manufactured with an UL marking on request.

							
- 40°C to +80°C	Flame retardant (NF C 32-070/C2, IEC 60332-1/2)	Low smoke emission and low opacity (IEC 61034)	Non corrosive and non toxic (IEC 60754-2)	Flexible	Screened versions	Halogen free (IEC 60754-1)	RoHS

## G250-ZH - Halogen free flexible pairs, screened with overall braid

Nb of pairs	Nexans Reference	Core			Braid		Overall diameter		Average weight Kg/Km
		Gauge AWG	Cross section mm <sup>2</sup>	Construction n x Ø mm	Ø strand	Ø mm	Ø mm	Tolerance mm	
<b>2</b>	<b>G250-ZH 2/2</b>	24	0.22	7 x 0.20	0.12	3.55	5.1	± 0.30	36
<b>3</b>	<b>G250-ZH 3/2</b>	24	0.22	7 x 0.20	0.12	4.00	5.50	± 0.40	44
<b>5*</b>	<b>G250-ZH 5/2</b>	24	0.22	7 x 0.20	0.12	5.1	6.6	± 0.40	64
<b>7</b>	<b>G250-ZH 7/2</b>	24	0.22	7 x 0.20	0.12	5.55	7.1	± 0.40	82
<b>10</b>	<b>G250-ZH 10/2</b>	24	0.22	7 x 0.20	0.13	6.60	8.1	± 0.40	106
<b>12</b>	<b>G250-ZH 12/2</b>	24	0.22	7 x 0.20	0.13	7.10	8.7	± 0.40	123
<b>15</b>	<b>G250-ZH 15/2</b>	24	0.22	7 x 0.20	0.13	7.95	9.6	± 0.50	147
<b>21</b>	<b>G250-ZH 21/2</b>	24	0.22	7 x 0.20	0.15	9.30	11.3	± 0.50	208
<b>25</b>	<b>G250-ZH 25/2</b>	24	0.22	7 x 0.20	0.15	10.40	12.7	± 0.40	242
<b>30</b>	<b>G250-ZH 30/2</b>	24	0.22	7 x 0.20	0.15	11.90	14.70	± 0.60	300

\* PVC filler

## Electrical characteristics

Attenuation	Value	Unit
Maximum loop resistance at 20°C	≤ 200	Ω/km
Insulation resistance at 20°C at 200 volts dc	≥ 500	MΩ.km

## G250-ZH colour coding

PAIR #	1	2	3	4	5	6	7	8	9	10
<b>WIRE 1</b>	Blue	Yellow	Brown	Black	Green	White/Blue	Yellow/Blue	Brown/Blue	Blue/Black	Green/Blue
<b>WIRE 2</b>	White	White	White	White	White	White	White	White	White	White

PAIR #	11	12	13	14	15	16	17	18	19	20
<b>WIRE 1</b>	White/Yellow	Yellow/Brown	Yellow/Black	Yellow/Green	White/Brown	Brown/Black	Brown/Green	White/Black	Green/Black	White/Green
<b>WIRE 2</b>	White	White	White	White	White	White	White	White	White	White

PAIR #	21	22	23	24	25	26	27	28	29	30
<b>WIRE 1</b>	Blue	Yellow	Brown	Black	Green	White/Blue	Yellow/Blue	Brown/Blue	Blue/Black	Green/Blue
<b>WIRE 2</b>	White/Red	White/Red	White/Red	White/Red	White/Red	White/Red	White/Red	White/Red	White/Red	White/Red

White/Blue = White ring Blue



**105°C**



# UL 1015

## Hook-up wires

### Applications

Those wires are mainly designed for internal wiring in electrical and electronic equipments. They are well suited to work under stringent conditions. They are both UL and RoHS qualified. They can be used in all equipments in Europe or world wide.

500 volts

### Construction

#### 1 - AME

Stranded tinned copper wires

#### 2 - ISOLATION

Polyvinyl chloride (PVC-UL)



### Standards

UL AWM Style 1015

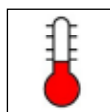

-20 °C to +105°C



Flame retardant  
UL VW-1

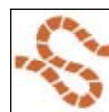

Flexible



RoHS

## ■ UL 1015 - Hook-up wires

Nexans Reference	Conductor			Overall diameter mm
	Gauge AWG	Cross section mm <sup>2</sup>	Construction n x Ø mm	
<b>UL 1015 600V 105 °C</b>	24	0.25	19 x 0.13	2.30 ± 0.10
<b>UL 1015 600V 105 °C</b>	22	0.38	19 x 0.16	2.45 ± 0.10
<b>UL 1015 600V 105 °C</b>	18	0.93	19 x 0.25	2.95 ± 0.10
<b>UL 1015 600V 105 °C</b>	16	1.3	19 x 0.30	3.10 ± 0.10
<b>UL 1015 600V 105 °C</b>	12	3.3	65 x 0.255	4.00 ± 0.12

# KY/EPDX

## Unscreened hook-up wires

### Applications

These wires are mainly designed for internal wiring in electronic equipment.

250 and 750 Volts

### Construction

#### 1- CONDUCTOR

Stranded annealed tinned copper wires

#### 2- INSULATION

High temperature polyvinyl chloride (PVC)



### Standards

NF C 93-521

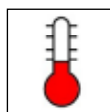

- 40°C to +105°C



Fire retardant  
(NF C 32-070/C1)

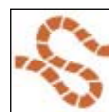

Flexible



RoHS

## KY/EPDX - Unscreened hook-up wires - 250 volts

Reference NFC 93 521	Nexans Reference	Conductor			Overall diameter		Average weight Kg/Km
		Gauge AWG	Cross section mm <sup>2</sup>	Construction n x Ø mm	Mini mm	Maxi mm	
<b>KY 30-01</b>	EPDX 6x0	30	0.055	7 x 0.10	0.70	0.80	1.0
<b>KY 30-02</b>	EPDX 5x0	28	0.079	7 x 0.12	0.76	0.86	1.3
<b>KY 30-03</b>	EPDX 4x0	26	0.12	7 x 0.15	0.80	1.00	1.7
<b>KY 30-04</b>	EPDX 000	24	0.22	7 x 0.20	1.00	1.20	2.8
<b>KY 30-05</b>	EPDX 00	22	0.34	7 x 0.25	1.20	1.45	4.3
<b>KY 30-06</b>	EPDX 26	20	0.60	19 x 0.20	1.60	1.90	7.4
<b>KY 30-07</b>	EPDX 27	18	0.93	19 x 0.25	1.85	2.15	11.0
<b>KY 30-08</b>	EPDX 28	16	1.34	19 x 0.30	2.20	2.50	15.5

## KY/EPDX - Unscreened hook-up wires - 750 volts

Reference NFC 93 521	Nexans Reference	Conductor			Overall diameter		Average weight Kg/Km
		Gauge AWG	Cross section mm <sup>2</sup>	Construction n x Ø mm	Mini mm	Maxi mm	
<b>KY 33 A 01</b>	<b>EPDX 6</b>	24	0.22	7 x 0.20	1.60	1.80	4.6
<b>KY 33 A 02</b>	<b>EPDX 7</b>	22	0.38	12 x 0.20	2.00	2.30	7.3
<b>KY 33 A 03</b>	<b>EPDX 16</b>	20	0.60	19 x 0.20	2.20	2.50	9.8
<b>KY 33 A 04</b>	<b>EPDX 17</b>	18	1.00	32 x 0.20	2.50	2.80	14.4
<b>KY 33 A 05</b>	<b>EPDX 8</b>	16	1.34	19 x 0.30	2.70	3.00	18.0
<b>KY 33 A 06</b>	<b>EPDX 9</b>	14	1.91	27 x 0.30	3.00	3.40	24.3
<b>KY 33 A 07</b>	<b>EPDX 10</b>	12	3.18	45 x 0.30	3.80	4.20	39.7
<b>KY 33 A 08</b>	<b>EPDX 14</b>	10	5.15	73 x 0.30	4.40	4.80	59.9
<b>KY 33 A 09</b>	<b>EPDX 15</b>	8	10.20	144 x 0.30	5.80	6.20	112.0

# KY/EPDX

Screened hook-up wires,  
screened and jacketed hook-up wires

## Applications

These wires are mainly designed for internal wiring in electronic equipment.

250 and 750 Volts

## Construction

### 1- CONDUCTOR

Stranded annealed tinned copper wires

### 2- INSULATION

High temperature polyvinyl chloride (PVC)

### 3- SCREEN

Tinned copper braid

### 4- OUTER JACKET

Polyvinyl chloride (PVC), or superpolyamide (P)

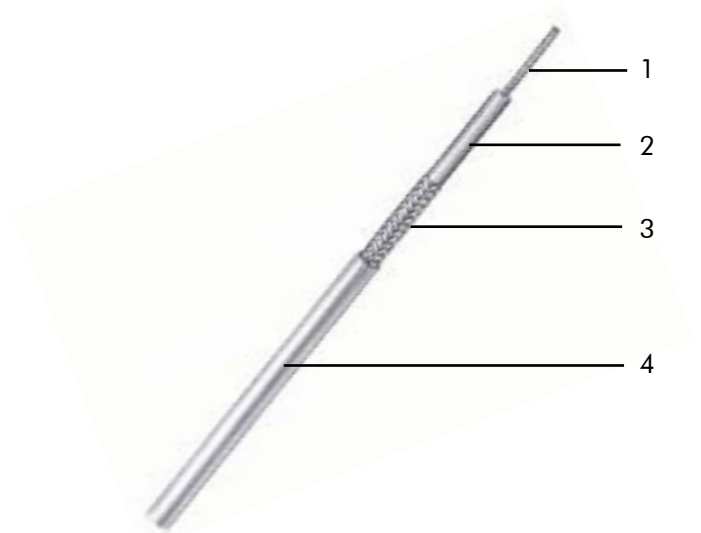

## Standards

NF C 93-521

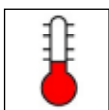

-40°C to +105°C



Fire retardant  
(NF C 32-070/C1)



Flexible



RoHS

## KY/EPDX - Screened hook-up wires

Nb of Cond.	Reference NFC93-521	Nexans Reference	Base Core				Braid		Overall Ø		Average weight Kg/Km
			Conductor			Nominal Ø core mm	Ø strands mm	kr %	mini	maxi	
			Gauge AWG	Cross section mm <sup>2</sup>	Construction n x Ø mm				mm		

### TYPE KY - 250 VOLTS - STRANDED CONDUCTOR

1	<b>KY 45-01</b>	EPDX 4x0 BL	26	0.12	7 x 0.15	0.90	0.10	55	1.2	1.7	4.8
	<b>KY 45-02</b>	EPDX 000 BL	24	0.22	7 x 0.20	1.10	0.10	55	1.4	1.9	6.6
	<b>KY 45-03</b>	EPDX 00 BL	22	0.34	7 x 0.25	1.30	0.10	60	1.6	2.2	8.5

### TYPE KY - 750 VOLTS - STRANDED CONDUCTOR

1	<b>KY 37 A 01</b>	EPDX 6 BL	24	0.22	7 x 0.20	1.70	0.10	60	1.9	2.4	10.2
	<b>KY 37 A 02</b>	EPDX 7 BL	22	0.38	12 x 0.20	2.15	0.12	65	2.4	3.1	16.5
	<b>KY 37 A 03</b>	EPDX 16 BL	20	0.60	19 x 0.20	2.35	0.12	65	2.6	3.3	19.9
	<b>KY 37 A 04</b>	EPDX 17 BL	18	1.00	32 x 0.20	2.65	0.12	65	2.9	3.6	25.5
	<b>KY 37 A 05</b>	EPDX 8 BL	16	1.34	19 x 0.30	2.85	0.12	65	3.1	3.8	30.2
	<b>KY 37 A 06</b>	EPDX 9 BL	14	1.91	27 x 0.30	3.20	0.12	70	3.4	4.2	39.0

## KY/EPDX - Screened and jacketed hook-up wires

Nb of Cond.	Reference NFC93-521	Nexans Reference	Base Core				Braid		Outer jacket nature	Overall Ø		Average weight Kg/Km
			Conductor			Nominal Ø core mm	Ø strands mm	kr %		mini	maxi	
			Gauge AWG	Cross section mm <sup>2</sup>	Construction n x Ø mm					mm		

### TYPE KY - 250 VOLTS - STRANDED CONDUCTOR

1	<b>KY 46-01</b>	EPDX4x0 BLP	26	0.12	7 x 0.15	0.90	0.10	55	P	1.4	2.1	5.2
	<b>KY 46-02</b>	EPDX3x0 BLP	24	0.22	7 x 0.20	1.10	0.10	55	P	1.6	2.3	7.4
	<b>KY 46-03</b>	EPDX 00 BLP	22	0.34	7 x 0.25	1.30	0.10	60	P	1.8	2.6	9.5

### TYPE KY - 750 VOLTS - STRANDED CONDUCTOR

1	<b>KY 44 A 01</b>	EPDX 6 BLP	24	0.22	7 x 0.20	1.7	0.10	60	P	2.1	2.8	11.2
	<b>KY 41 A 02</b>	EPDX 7 BLI	22	0.38	12 x 0.20	2.15	0.12	65	PVC	3.6	4.5	26.2
	<b>KY 44 A 02</b>	EPDX 7 BLP	22	0.38	12 x 0.20	2.15	0.12	65	P	2.6	3.5	17.7
	<b>KY 41 A 03</b>	EPDX 16 BLI	20	0.60	19 x 0.20	2.35	0.12	65	PVC	3.8	4.7	30.0
	<b>KY 44 A 03</b>	EPDX 16 BLP	20	0.60	19 x 0.20	2.35	0.12	65	P	2.8	3.7	21.2
	<b>KY 41 A 04</b>	EPDX17BLI	18	1.0	32 x 0.20	2.65	0.12	65	PVC	4.1	5.0	36.6
	<b>KY 44 A 04</b>	EPDX17BLP	18	1.0	32 x 0.20	2.65	0.12	65	P	3.1	4.0	26.9
	<b>KY 41 A 05</b>	EPDX8 BLI	16	1.34	19 x 0.30	2.85	0.12	65	PVC	4.3	5.2	41.9
	<b>KY 44 A 05</b>	EPDX8 BLP	16	1.34	19 x 0.30	2.85	0.12	65	P	3.3	4.2	31.7
	<b>KY 41 A 06</b>	EPDX 9 BLI	14	1.91	27 x 0.30	3.20	0.12	70	PVC	4.6	5.5	51.4
<b>KY 44 A 06</b>	EPDX 9BLP	14	1.91	27 x 0.30	3.20	0.12	70	P	3.6	4.6	40.6	

Reference.. BLI : PVC outer jacket giving a good mechanical protection and electrical insulation

Reference.. BLP : Superpolyamide outer jacket providing only a mechanical protection

### Applications

Flexible cables and lightweight range with PVC + superpolyamide insulation for use in low temperature areas.

Good abrasion resistance.

They withstand most chemical fluids except for concentrated nitric acid.

**600 Volts RMS**

### Construction

#### 1- CONDUCTOR

Stranded tinned copper wires or stranded tinned copper alloy wires for the cross section area 0.21 mm<sup>2</sup>

#### 2- INSULATION

Polyvinyl chloride (PVC)

#### 3- OUTER JACKET

Superpolyamide (radial thickness : from 0.10 mm up to 0.15 mm)



### Technical requirements and control conditions

Air 4524 specification of September 1965 - The 105/135°C cat.  
NFL 52-120B - BNAé specification of December 1971 -  
Lightweight cables.

### Colour coding

To AIR 0107A specification of October 1961.

### Interchangeability

MIL-W-5086 B/7 U.S. specification (December 1970).  
AICMA N° 5102 specification (December 1962).

### Standards

To AIR 4524 and MIL.W 5086 B/7A specifications.  
These cables are approved by the Air Ministry under letters:  
N° 41762 STA/EQ/E2 (12-11-68) for AWG22 up to AWG 8  
N° 33587 STA/EQ/E2 (30-3-72) for AWG24  
Registered at B.N.Aé:  
N° 6412 411 A

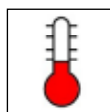

- 40°C to +105°C



Fire retardant  
(NF C 32-070/C1)



Flexible



RoHS

## 1604 - Unscreened hook-up wires

Nexans Reference			Conductor			Core		DC resist. at 20°C (maxi.) $\Omega / \text{km}$	Current rating A	Colour of cores
Type	Cross section	AWG	Construction n x $\varnothing$ mm	Nominal $\varnothing$ mm	Tensile strength daN.	Overall $\varnothing$ mm	Average weight Kg/Km			
<b>1604</b>	<b>0.21</b>	<b>24</b>	19 x 0.12 T.P.C. All.	0.60	7	1.38 $\pm$ 0.07	3.4	105.0	4	Light Blue
<b>1604</b>	<b>0.38</b>	<b>22</b>	12 x 0.20 T.P.C.	0.80	8	1.50 $\pm$ 0.07	5.1	50.9	7	White
<b>1604</b>	<b>0.60</b>	<b>20</b>	19 x 0.20 T.P.C.	1.00	16	1.70 $\pm$ 0.07	7.5	32.2	11	Light Blue
<b>1604</b>	<b>0.93</b>	<b>18</b>	19 x 0.25 T.P.C..	1.20	20	2.0 $\pm$ 0.07	11.0	20.6	16	White
<b>1604</b>	<b>1.34</b>	<b>16</b>	19 x 0.30 T.P.C.	1.50	20	2.30 $\pm$ 0.10	14.0	14.3	22	Light Blue
<b>1604</b>	<b>1.91</b>	<b>14</b>	27 x 0.30 T.P.C.	1.80	20	2.70 $\pm$ 0.10	21.6	10.1	32	White
<b>1604</b>	<b>3.18</b>	<b>12</b>	45 x 0.30 T.P.C.	2.30	20	3.50 $\pm$ 0.10	36.1	6.0	41	White
<b>1604</b>	<b>5.15</b>	<b>10</b>	73 x 0.30 T.P.C.	3.00	20	4.20 +0.10 / -0.20	55.1	3.7	55	White
<b>1604</b>	<b>8.98</b>	<b>8</b>	127 x 0.30 T.P.C.	3.80	20	5.50 +0.10 / -0.20	90.2	2.1	75	White

The shown current rating is valid for singles wires in air.

### Applications

Flexible cables and lightweight range with PVC + superpolyamide insulation for use in low temperature areas.

Good abrasion resistance.

They withstand most chemical fluids except for concentrated nitric acid.

**600 Volts RMS**

### Construction

#### BASE CORE 1604

#### 1- CONDUCTOR

Stranded tinned copper wires or stranded tinned copper alloy wires for cross section 0.21mm

#### 2- INSULATION

Polyvinyl chloride (PVC )

#### 3- OUTER JACKET

Superpolyamide (radial thickness : from 0.10 mm up to 0,15 mm)

#### 604

#### 4- LAY UP

1 or several 1604 cores

#### 5- SCREEN

Tinned copper braid (Kr ≥ 62%)

#### 6- OUTER JACKET

Superpolyamide (radial thickness : about 0.20mm)

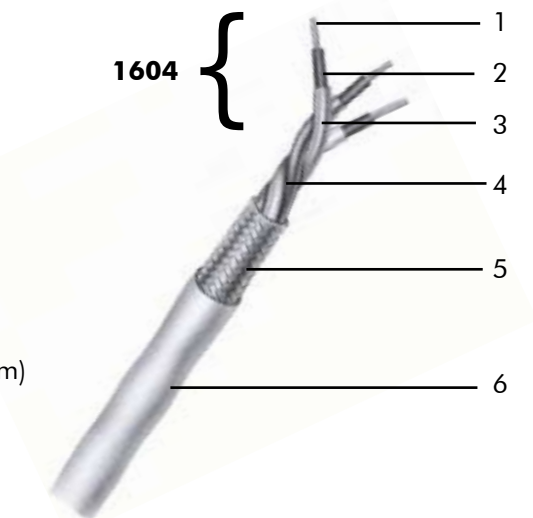

### Technical requirements and control conditions

Screen : to MIL.C. 7078C (August 1971) U.S. specification

### Colour coding

To Air 0107 A (October 1961) and note N° 348/SIB distributed under n° 5927/STT/SIB (3 May 1961).

### Standards

To AIR 4524 & MIL-W 5086B/7A specifications.

These cables are approved by the Air Ministry under letters:

N° 33587 STA/EQ/E2 (30-3-72) for AWG 24

N° 41762 STA/EQ/E2 (12-11-68) for AWG 22 up to AWG 8

Registered at B.N.Aé : N° 6412 411 A

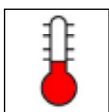

-40°C to +105°C



Fire retardant (NF C 32-070/C1)



Flexible



## 604 - Screened and jacketed hook-up wires and multicore cables

Nb of cores	Nexans Reference				Base Core : 1604			Serie 604		
					Construction n x Ø mm	Overall Ø nominal mm	Colour coding of cores	Colour of outer jacket	Overall Ø (maxi.) mm	Average weight Kg/Km
1	604	1	0.21	G 24	19 x 0.12 T.P.C All	1.38	Light blue	Light blue	2.25	9.0
	604	1	0.38	G 22	12 x 0.20 T.P.C.	1.50	White	White	2.55	11.7
	604	1	0.60	G 20	19 x 0.20 T.P.C.	1.70	Light blue	Light blue	2.75	14.7
	604	1	0.93	G 18	19 x 0.25 T.P.C.	2.00	White	White	3.05	19.2
	604	1	1.34	G 16	19 x 0.30 T.P.C.	2.30	Light blue	Light blue	3.35	25.0
	604	1	1.91	G 14	27 x 0.30 T.P.C.	2.70	White	White	3.75	31.8
	604	1	3.18	G 12	45 x 0.30 T.P.C.	3.50	White	White	4.73	51.2
2	604	2	0.21	G 24	19 x 0.12 T.P.C All	1.38	Light blue + Blue	Light blue	3.70	5.6
	604	2	0.38	G 22	12 x 0.20 T.P.C.	1.50	White + Blue	White	4.10	20.6
	604	2	0.60	G 20	19 x 0.20 T.P.C.	1.70	Light blue + Blue	Light blue	4.50	27.9
	604	2	0.93	G 18	19 x 0.25 T.P.C.	2.00	White + blue	White	5.10	37.5
	604	2	1.34	G 16	19 x 0.30 T.P.C.	2.30	Light blue + Blue	Light blue	5.70	49.2
	604	2	1.91	G 14	27 x 0.30 T.P.C.	2.70	White + Blue	White	6.60	62.9
	604	2	3.18	G 12	45 x 0.30 T.P.C.	3.50	White + Blue	White	8.56	102.9
3	604	3	0.21	G 24	19 x 0.12 T.P.C All	1.38	Light blue + Blue + Yellow	Light blue	3.95	22.6
	604	3	0.38	G 22	12 x 0.20 T.P.C.	1.50	White + Blue + Yellow	White	4.35	29.8
	604	3	0.60	G 20	19 x 0.20 T.P.C.	1.70	Light blue + Blue + Yellow	Light blue	4.80	38.6
	604	3	0.93	G 18	19 x 0.25 T.P.C.	2.00	White + Blue + Yellow	White	5.45	51.7
	604	3	1.34	G 16	19 x 0.30 T.P.C.	2.30	Light blue + Blue + Yellow	Light blue	6.10	68.6
	604	3	1.91	G 14	27 x 0.30 T.P.C.	2.70	White + Blue + Yellow	White	7.00	88.5
	604	3	3.18	G 12	45 x 0.30 T.P.C.	3.50	White + Blue + Yellow	White	9.11	145.6
4	604	4	0.21	G 24	19 x 0.12 T.P.C All	1.38	Light Blue + Blue + Yellow + Green	Light blue	4.40	28.4
	604	4	0.38	G 22	12 x 0.20 T.P.C.	1.50	White + Blue+ Yellow + Green	White	4.90	37.8
	604	4	0.60	G 20	19 x 0.20 T.P.C.	1.70	Light blue + Blue + Yellow + Green	Light blue	5.40	49.1
	604	4	0.93	G 18	19 x 0.25 T.P.C.	2.00	White + Blue + Yellow + Green	White	6.10	66.4
	604	4	1.34	G 16	19 x 0.30 T.P.C.	2.30	Light blue + Blue + Yellow + Green	Light blue	7.00	88.6
	604	4	1.91	G 14	27 x 0.30 T.P.C.	2.70	White + Blue + Yellow + Green	White	7.90	121.0
	604	4	3.18	G 12	45 x 0.30 T.P.C.	3.50	White + Blue + Yellow + Green	White	10.06	186.9

# 1625 A

## Unscreened hook-up wires

### Applications

Flexible cables for use in low temperature areas up to 135°C at peak.

Excellent resistance to abrasion and short-circuits.

They withstand most chemical fluids.

They are non-flammable.

600 Volts RMS

### Construction

#### 1- CONDUCTOR

Stranded tinned copper wires or stranded tinned copper alloy wires for cross section 0.21mm (good mechanical resistance)

#### 2- INSULATION

Polyvinyl chloride (PVC)

#### 3- Braid of fibre glass

With non-flammable varnish

#### 4- OUTER SHEATH

##### a) From 0.21 to 3.18 mm<sup>2</sup>:

superpolyamide braid (high resistance to abrasion)

##### b) From 3.18 mm<sup>2</sup> :

superpolyamide braid with a special varnish

Cross sections from 0.21 mm<sup>2</sup> to 3.18 mm<sup>2</sup>



Cross sections from 5.15 mm<sup>2</sup>

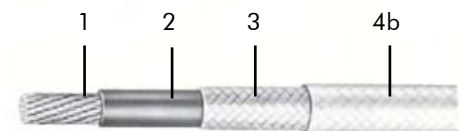

### Technical requirements and control conditions

Air 4524 specification of September 1965 - The 105/135°C cat.

### Colour coding

To AIR 0107A specification of October 1961.

### Standards

To AIR 4524

These cables are approved by the

Air Ministry under letters:

N°34438 STA/EQ.E2 (14-04-62)

N°40221 STA/EQ.E2 (05-10-64)

for cross sections >0.38 mm<sup>2</sup>

N°32660 STA/EQ/E2 (10-03-70)

for 0.21 mm<sup>2</sup> cross section

Registered at B.N.Aé :

N° 6411 401E

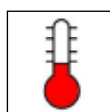

- 55°C to +105°C



AIR 4524



Flexible



RoHS

## 1625 A - Unscreened hook-up wires

Nexans Reference	US AWG	Conductor			Finished cable			
		Construction n x Ø mm	Overall Ø mm		DC resist. at 20°C Ω / km	Overall Ø mm		Average weight Kg/Km
			Nom.	Max.		Max.	Nom.	
<b>1625 A 0.21 G.24</b>	<b>24</b>	19 x 0.12	0.58	0.65	105	1.54	1.70	5.50
<b>1625 A 0.38 G.22</b>	<b>22</b>	12 x 0.20	0.77	0.85	50.9	1.84	2	6.80
<b>1625 A 0.60 G.20</b>	<b>20</b>	19 x 0.20	0.97	1.03	32.2	2.04	2.30	10.10
<b>1625 A 0.93 G.18</b>	<b>18</b>	19 x 0.25	1.22	1.28	20.6	2.29	2.50	14.00
<b>1625 A 1.34 G.16</b>	<b>16</b>	19 x 0.30	1.46	1.53	14.3	2.64	2.80	17.70
<b>1625 A 1.91 G.14</b>	<b>14</b>	27 x 0.30	1.75	1.87	10.1	2.94	3.30	27.20
<b>1625 A 3.18 G.12</b>	<b>12</b>	45 x 0.30	2.26	2.40	6	3.71	3.80	38.60
<b>1625 A 5.15 G.10</b>	<b>10</b>	73 x 0.30	2.87	3.10	3.6	4.28	5.00	65.40
<b>1625 A 8.98 G.8</b>	<b>8</b>	127 x 0.30	3.79	4.20	2.1	5.49	6.03	103.50
<b>1625 A 13.40 G.6</b>	<b>6</b>	27 x 7 x 0.30	5.15	5.60	1.48	7.03	7.60	163.00
<b>1625 A 21.80 G.4</b>	<b>4</b>	37 x 12 x 0.25	6.58	7.30	0.91	9.03	9.30	244.50
<b>1625 A 34.50 G.2</b>	<b>2</b>	37 x 19 x 0.25	8.28	8.80	0.57	10.90	11.00	370.00
<b>1625 A 41.80 G.1</b>	<b>1</b>	37 x 23 x 0.25	9.11	9.80	0.47	12.10	12.20	452.00
<b>1625 A 52.70 G.0</b>	<b>0</b>	37 x 29 x 0.25	10.23	10.80	0.373	13.60	13.70	592.00
<b>1625 A 67.20 G.00</b>	<b>00</b>	37 x 37 x 0.25	11.55	12.40	0.293	15.00	15.40	740.00
<b>1625 A 84.80 G.000</b>	<b>000</b>	48 x 36 x 0.25	12.98	13.80	0.232	16.60	16.90	918.00
<b>1625 A 108 G.0000</b>	<b>0000</b>	61 x 36 x 0.25	14.63	15.50	0.184	18.30	18.60	1160.00

# FLAMEX SH20

Unscreened halogen free hook-up wires,  
screened and jacketed hook-up wires

## Applications

Strictly halogen free, these wires combine the advantages of small size, lightweight, high chemical resistance, high mechanical properties.

Designed to conform to EN 50306 and NF F 63-808 standards, these cables are particularly recommended for the rolling stock market

Flamex SH20 - 600 Vac / 1000 Vcc

## Construction

### 1- Conductor

Stranded tinned copper wires

### 2- Insulation

Thin wall halogen free,  
FLAMEX SH20

### 3- Screen

(screened versions)

Tinned copper braid with optional polyester tape

### 4- Outer sheath

(screened versions)

Halogen free FLAMEX

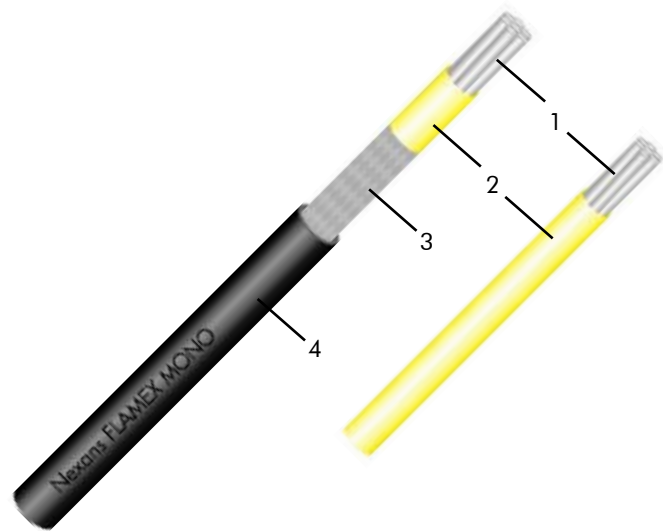

Single core and multicore cables

## Colour coding

For NF F 63-808 cables :

0.60	0.93	1.34	1.82	2.61	4.32
AWG20	AWG18	AWG16	AWG14	AWG14	AWG12
Yellow	White	Green	Yellow	White	Green

For EN 50306 cables :

Insulation : white, numbered 1 to n

Colour coded wires on request

Sheath : black

## Standards

NF F 63-808, EN 50306.

- 40°C to +105°C	Good chemical resistance (acids, oils, ...) IRM 902, IRM 903	Flame and fire retardant (NF C 32-070/C1 & C2, IEC 60332-1/2/3, Cat.C and EN 50306-1)	Low smoke emission and low opacity (IEC 61034)	Non corrosive and non toxic (IEC 60754-2 and EN 50267)	Flexible	EMI	Halogen free (IEC 60754-1)

**Flamex SH20 - NF F 63-808**  
**Unscreened and unsheathed single core cables**

Designation	Nexans reference	Conductor				Overall Ø		Average weight Kg/km
		Gauge AWG	Cross section mm <sup>2</sup>	Construction n x Ø mm	Maxi. Ø mm	mini. mm	maxi. mm	
<b>FLAMEX 20 0.60</b>	<b>2PF503</b>	20	0.60	19x0.20 TC	1.05	1.30	1.50	6.60
<b>FLAMEX 20 0.93</b>	<b>2PF272</b>	18	0.93	19x0.25 TC	1.30	1.55	1.75	10.00
<b>FLAMEX 20 1.34</b>	<b>2PF505</b>	16	1.34	19x0.30 TC	1.55	1.80	2.00	14.00
<b>FLAMEX 20 1.82</b>	<b>2PF507</b>	14	1.82	37x0.25 TC	1.82	2.10	2.40	19.20
<b>FLAMEX 20 2.61</b>	<b>2PF508</b>	14	2.61	37x0.30 TC	2.28	2.50	2.80	27.80
<b>FLAMEX 20 4.32</b>	<b>2PF509</b>	12	4.32	61x0.30 TC	2.90	3.00	3.30	44.20

**Flamex SH20 - NF F 63-808**  
**Screened and sheathed single core cables (with thin wall sheathed)**

Designation	Nexans reference	Conductor				Overall diameters		Average weight Kg/km
		Gauge AWG	Cross section mm <sup>2</sup>	Construction n x Ø mm	Maxi. Ø mm	Insulation Nominal Ø mm	Cable Nominal Ø mm	
<b>FLAMEX 20 0.60 BLG</b>	<b>2PF514</b>	20	0.60	19x0.20 TC	1.05	1.40 ± 0.10	2.55 ± 0.25	15.00
<b>FLAMEX 20 0.93 BLG</b>	<b>2PF407</b>	18	0.93	19x0.25 TC	1.30	1.65 ± 0.10	2.75 ± 0.25	19.00
<b>FLAMEX 20 1.34 BLG</b>	<b>2PF516</b>	16	1.34	19x0.30 TC	1.55	1.90 ± 0.10	2.95 ± 0.25	24.00

**Flamex SH20 - EN 50306-2 Table 1 Category M**  
**Unscreened and unsheathed single core cables (with thin wall sheathed)**

Designation	Nexans reference	Conductor			Insulation Ø		Maxi. cond. resistance Ohms/km	Average weight Kg/km
		Cross section mm <sup>2</sup>	Construction n x Ø mm	Ø maxi. mm	mini. mm	maxi. mm		
<b>FLAMEX 20 EN 50306-2 1X0.5 -M</b>	<b>2PG198</b>	0.50	19x0.18 TC	0.95	1.15	1.45	40.1	6.0
<b>FLAMEX 20 EN 50306-2 1X0.75 -M</b>	<b>2PG199</b>	0.75	19x0.23 TC	1.15	1.35	1.65	26.7	8.5
<b>FLAMEX 20 EN 50306-2 1X1.0 -M</b>	<b>2PG200</b>	1.00	19x0.25 TC	1.30	1.45	1.80	20.0	10.5
<b>FLAMEX 20 EN 50306-2 1X1.5 -M</b>	<b>2PF779</b>	1.50	37x0.23 TC	1.65	1.95	2.30	13.7	16.0
<b>FLAMEX 20 EN 50306-2 1X2.5 -M</b>	<b>2PG201</b>	2.50	37x0.30 TC	2.15	2.50	2.85	8.21	26.5

**Flamex SH20 - EN 50306-3 Table 1 Category MM**  
**Screened and sheathed single core cables (with thin wall sheathed)**

Designation	Nexans ref.	Conductor			Insulation		Overall Ø		Average weight Kg/Km
		Cross section mm <sup>2</sup>	Construction n x Ø mm	Ø maxi. mm	Mini. mm	Maxi. mm	Mini. mm	Maxi. mm	
<b>FLAMEX 20 EN 50306-3 1 x 0.50 MM S</b>	<b>2PH184</b>	0.50	19x0.18 TC	0.95	1.15	1.45	2.30	2.80	14
<b>FLAMEX 20 EN 50306-3 1 x 0.75 MM S</b>	<b>2PH185</b>	0.75	19x0.23 TC	1.15	1.35	1.65	2.50	3.00	17
<b>FLAMEX 20 EN 50306-3 1 x 1.00 MM S</b>	<b>2PH186</b>	1.00	19x0.25 TC	1.30	1.45	1.80	2.70	3.20	20
<b>FLAMEX 20 EN 50306-3 1 x 1.50 MM S</b>	<b>2PH187</b>	1.50	37x0.23 TC	1.65	1.95	2.30	3.10	3.60	28
<b>FLAMEX 20 EN 50306-3 1 x 2.50 MM S</b>	<b>2PH188</b>	2.50	37x0.30 TC	2.15	2.50	2.85	3.60	4.40	43

TC = Tinned copper

# FLAMEX SH20

Screened and jacketed,  
halogen free multicore cables

## Applications

Strictly halogen free, these wires combine the advantages of small size, lightweight, high chemical resistance, high mechanical properties.  
Designed to conform to EN 50306 and NF F 63-808 standards, this cables are particularly recommended for the rolling stock market

Flamex SH20 - 600 Vac / 1000 Vcc

## Construction

### 1- Conductor

Stranded tinned copper wires

### 2- Insulation

Thin wall halogen free,  
FLAMEX SH20

### 3- Screen

Tinned copper braid with optional polyester tape

### 4- Outer sheath

Halogen free FLAMEX



## Colour coding

For NF F 63-808 cables :

0.60	0.93	1.34	1.82	2.61	4.32
AWG20	AWG18	AWG16	AWG14	AWG14	AWG12
Yellow	White	Green	Yellow	White	Green

For EN 50306 cables :







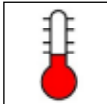
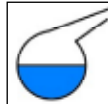

Insulation : white, numbered 1 to n

Colour coded wires on request

Sheath : black

## Standards

NF F 63-808, EN 50306.

							
- 40°C to +105°C	Good chemical resistance (acids, oils, ...) IRM 902, IRM 903	Flame and fire retardant (NF C 32-070/C1 & C2, IEC 60332-1/2/3, Cat.C and EN 50306-1)	Low smoke emission and low opacity (IEC 61034)	Non corrosive and non toxic (IEC 60754-2 and EN 50267)	Flexible	EMI	Halogen free (IEC 60754-1)
							

**Flamex SH20 - NF F 63-808 (insulation and sheath)  
Screened and sheathed multicore cable (thin wall sheath)**

Nb of cores	Designation	Nexans ref.	Overall diameters		Average weight Kg/km
			Insulation Nominal Ø mm	Cable Nominal Ø mm	
2	<b>FLAMEX 20 2x 0.38 BLG</b>	<b>2PF523</b>	1.25 ± 0.10	3.60 ± 0.40	20.00
	<b>FLAMEX 20 2x 0.60 BLG</b>	<b>2PF525</b>	1.40 ± 0.10	4.10 ± 0.40	30.00
	<b>FLAMEX 20 2x 0.93 BLG</b>	<b>2PF273</b>	1.65 ± 0.10	4.65 ± 0.40	39.00
	<b>FLAMEX 20 2x 1.34 BLG</b>	<b>2PF527</b>	1.90 ± 0.10	5.20 ± 0.40	52.00
	<b>FLAMEX 20 2x 1.82 BLG</b>	<b>2PF529</b>	2.25 ± 0.15	5.95 ± 0.40	67.00
	<b>FLAMEX 20 2x 2.61 BLG</b>	<b>2PF530</b>	2.65 ± 0.15	6.75 ± 0.40	87.00
	<b>FLAMEX 20 2x 4.32 BLG</b>	<b>2PF531</b>	3.15 ± 0.15	7.90 ± 0.40	128.00
3	<b>FLAMEX 20 3x 0.38 BLG</b>	<b>2PF533</b>	1.25 ± 0.10	3.95 ± 0.40	30.00
	<b>FLAMEX 20 3x 0.60 BLG</b>	<b>2PF535</b>	1.40 ± 0.10	4.40 ± 0.40	39.00
	<b>FLAMEX 20 3x 0.93 BLG</b>	<b>2PF537</b>	1.65 ± 0.10	4.90 ± 0.40	52.00
	<b>FLAMEX 20 3x 1.34 BLG</b>	<b>2PF538</b>	1.90 ± 0.10	5.50 ± 0.40	66.00
	<b>FLAMEX 20 3x 1.82 BLG</b>	<b>2PF540</b>	2.25 ± 0.15	6.20 ± 0.40	84.00
	<b>FLAMEX 20 3x 2.61 BLG</b>	<b>2PF541</b>	2.65 ± 0.15	7.20 ± 0.40	117.00
	<b>FLAMEX 20 3x 4.32 BLG</b>	<b>2PF542</b>	3.15 ± 0.15	8.50 ± 0.40	182.00
4	<b>FLAMEX 20 4x 0.38 BLG</b>	<b>2PF544</b>	1.25 ± 0.10	4.45 ± 0.40	39.00
	<b>FLAMEX 20 4x 0.60 BLG</b>	<b>2PF546</b>	1.40 ± 0.10	4.90 ± 0.40	51.00
	<b>FLAMEX 20 4x 0.93 BLG</b>	<b>2PF548</b>	1.65 ± 0.10	5.40 ± 0.40	70.00
	<b>FLAMEX 20 4x 1.34 BLG</b>	<b>2PF549</b>	1.90 ± 0.10	6.10 ± 0.40	89.00
	<b>FLAMEX 20 4x 1.82 BLG</b>	<b>2PF551</b>	2.25 ± 0.15	6.85 ± 0.40	109.00
	<b>FLAMEX 20 4x 2.61 BLG</b>	<b>2PF552</b>	2.65 ± 0.15	8.05 ± 0.40	157.00
	<b>FLAMEX 20 4x 4.32 BLG</b>	<b>2PF553</b>	3.15 ± 0.15	9.45 ± 0.40	237.00

**Flamex SH20 - EN 50306-3 Table 1 Category MM  
Screened and sheathed multicore cables (with thin wall sheathed)**

Nb of cores	Designation	Nexans ref.	Conductor			Insulation		Overall Ø		Average weight Kg/Km
			Cross section mm <sup>2</sup>	Construction n x Ø mm	Ø maxi mm	Mini mm	Maxi mm	Mini mm	Maxi mm	
2	<b>FLAMEX 20 EN 50306-3 2 x 0.50 MM S</b>	<b>2PG960</b>	0.50	19x0.18 TC	0.95	1.15	1.45	3.50	4.30	25
3	<b>FLAMEX 20 EN 50306-3 3 x 0.50 MM S</b>	<b>2PG963</b>		19x0.18 TC	0.95	1.15	1.45	3.70	4.50	33
4	<b>FLAMEX 20 EN 50306-3 4 x 0.50 MM S</b>	<b>2PH189</b>		19x0.18 TC	0.95	1.15	1.45	4.00	5.00	43
2	<b>FLAMEX 20 EN 50306-3 2 x 0.75 MM S</b>	<b>2PG961</b>	0.75	19x0.23 TC	1.15	1.35	1.65	3.90	4.70	31
3	<b>FLAMEX 20 EN 50306-3 3 x 0.75 MM S</b>	<b>2PG964</b>		19x0.23 TC	1.15	1.35	1.65	4.00	5.00	43
4	<b>FLAMEX 20 EN 50306-3 4 x 0.75 MM S</b>	<b>2PH190</b>		19x0.23 TC	1.15	1.35	1.65	4.50	5.50	56
2	<b>FLAMEX 20 EN 50306-3 2 x 1.00 MM S</b>	<b>2PG962</b>	1.00	19x0.25 TC	1.30	1.45	1.80	4.20	5.20	37
3	<b>FLAMEX 20 EN 50306-3 3 x 1.00 MM S</b>	<b>2PG965</b>		19x0.25 TC	1.30	1.45	1.80	4.50	5.50	52
4	<b>FLAMEX 20 EN 50306-3 4 x 1.00 MM S</b>	<b>2PG966</b>		19x0.25 TC	1.30	1.45	1.80	5.00	6.00	65
2	<b>FLAMEX 20 EN 50306-3 2 x 1.50 MM S</b>	<b>2PF780</b>	1.50	37x0.23 TC	1.65	1.95	2.30	5.10	6.10	55
3	<b>FLAMEX 20 EN 50306-3 3 x 1.50 MM S</b>	<b>2PH191</b>		37x0.23 TC	1.65	1.95	2.30	5.40	6.40	75
4	<b>FLAMEX 20 EN 50306-3 4 x 1.50 MM S</b>	<b>2PH192</b>		37x0.23 TC	1.65	1.95	2.30	6.00	7.00	100
2	<b>FLAMEX 20 EN 50306-3 2 x 2.50 MM S</b>	<b>2PH193</b>	2.50	37x0.30 TC	2.15	2.50	2.85	6.40	7.40	87
3	<b>FLAMEX 20 EN 50306-3 3 x 2.50 MM S</b>	<b>2PH194</b>		37x0.30 TC	2.15	2.50	2.85	6.80	7.80	124
4	<b>FLAMEX 20 EN 50306-3 4 x 2.50 MM S</b>	<b>2PH195</b>		37x0.30 TC	2.15	2.50	2.85	7.50	8.50	158

TC = Tinned copper

**Flamex SH20 - NF F 63-808 (insulation), NF F 63-826 (sheath)**  
**Unscreened and screened, sheathed multicore cables**  
 (with thick wall sheath for external use)

Designation	Conductor				Overall Ø	
	Gauge AWG	Cross section mm <sup>2</sup>	Construction n x Ø mm	Maxi. Ø mm	mini. mm	maxi. mm
<b>FLAMEX 20 0.93</b>	18	0.93	19x0.25 TC	1.30	1.55	1.75
<b>FLAMEX 20 1.34</b>	16	1.34	19x0.30 TC	1.55	1.80	2.00
<b>FLAMEX 20 1.82</b>	14	1.82	37x0.25 TC	1.82	2.10	2.40

Nb of cores	Nexans designation	Section mm <sup>2</sup>	Nexans reference	Overall Ø	
				mini. mm	maxi. mm
<b>WITHOUT OVERALL SCREEN</b>					
2	<b>FLAMEX 20 2 x 0.93 63808/826</b>	<b>0.93</b>	<b>2PF659</b>	5.50	6.50
3	<b>FLAMEX 20 3 x 0.93 63808/826</b>		<b>296584</b>	5.75	6.75
4	<b>FLAMEX 20 4 x 0.93 63808/826</b>		<b>2PF554</b>	6.50	7.30
7	<b>FLAMEX 20 7 x 0.93 63808/826</b>		<b>2PF408</b>	7.20	8.20
13	<b>FLAMEX 20 13 x 0.93 63808/826</b>		<b>2PF555</b>	9.50	10.80
19	<b>FLAMEX 20 19 x 0.93 63808/826</b>		<b>2PF556</b>	10.40	11.70
37	<b>FLAMEX 20 37 x 0.93 63808/826</b>		<b>2PF660</b>	14.10	16.20
2	<b>FLAMEX 20 2 x 1.34 63808/826</b>	<b>1.34</b>	<b>2PF557</b>	6.00	7.00
4	<b>FLAMEX 20 4 x 1.34 63808/826</b>		<b>296585</b>	6.80	7.80
7	<b>FLAMEX 20 7 x 1.34 63808/826</b>		<b>2PG411</b>	7.70	9.00
13	<b>FLAMEX 20 13 x 1.34 63808/826</b>		<b>2PF604</b>	10.20	12.00
19	<b>FLAMEX 20 19 x 1.34 63808/826</b>		<b>2PG412</b>	13.00	14.90
37	<b>FLAMEX 20 37 x 1.34 63808/826</b>		<b>2PF558</b>	15.60	17.70
3x2	<b>FLAMEX 20 3 x (BLG 2x1.34) 63808/826</b>		<b>2PF561</b>	13.20	14.80
7x2	<b>FLAMEX 20 7 x (BLG 2x1.34) 63808/826</b>	<b>2PF562</b>	16.80	18.60	
19	<b>FLAMEX 20 19 x 1.82 63808/826</b>	<b>1.82</b>	<b>2PG400</b>	13.00	14.20
37	<b>FLAMEX 20 37 x 1.82 63808/826</b>		<b>2PF559</b>	16.70	19.30
61	<b>FLAMEX 20 61 x 1.82 63808/826</b>		<b>2PF560</b>	21.30	23.70
<b>WITH OVERALL SCREEN</b>					
2	<b>FLAMEX 20 2 x 0.93 BLG 63808/826</b>	<b>0.93</b>	<b>2PF409</b>	6.00	6.80
3	<b>FLAMEX 20 3 x 0.93 BLG 63808/826</b>		<b>2PF563</b>	6.00	7.00
4	<b>FLAMEX 20 4 x 0.93 BLG 63808/826</b>		<b>2PF564</b>	6.90	7.60
2	<b>FLAMEX 20 2 x 1.34 BLG 63808/826</b>	<b>1.34</b>	<b>2PF565</b>	6.50	7.30



# EPDX-ZH, KY TYPE

Halogen free  
unscreened hook-up wires

## Applications

These wires are mainly designed for internal wiring in electronic equipment. Halogen free, they are intended to be used in places where the protection of the people and equipment is vital.

We recommend to use them for cabinet wiring in public areas such as railway or subway stations but also in industrial areas, etc...

250 and 750 Volts

## Construction

### 1- CONDUCTOR

Stranded annealed tinned copper wires





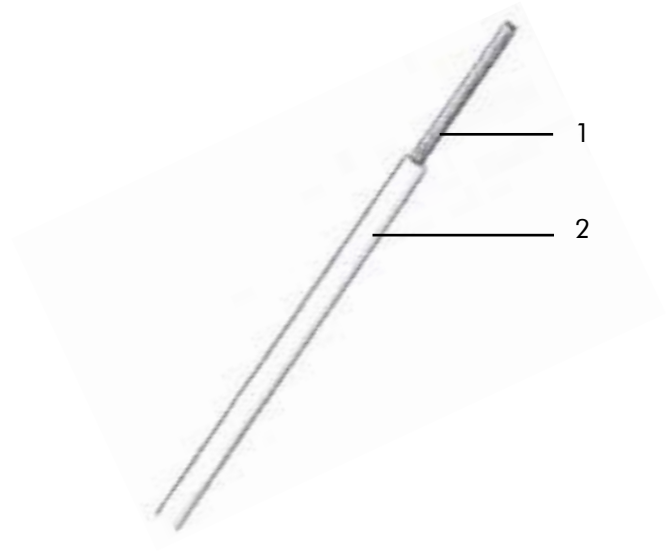

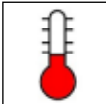

### 2- INSULATION

Halogen free



## Standards

NEXANS specification

							
- 40°C to +105°C	Flame retardant (NF C 32-070/C2, IEC 60332-1/2)	Low smoke emission and low opacity (IEC 61034)	Non corrosive and non toxic (IEC 60754-2)	Flexible	Screened versions	Halogen free (IEC 60754-1)	RoHS

Single core and multicore cables

## KY/EPDX-ZH, KY type - Halogen free unscreened hook-up wires - 250 volts

Nexans Reference	Conductor			Overall diameter mm	Average weight Kg/Km
	Gauge AWG	Cross section mm <sup>2</sup>	Construction n x Ø mm		
<b>EPDX-ZH 6x0</b>	30	0.055	7 x 0.10	0.75 ± 0.05	1.05
<b>EPDX-ZH 5x0</b>	28	0.079	7 x 0.12	0.81 ± 0.05	1.35
<b>EPDX-ZH 4x0</b>	26	0.120	7 x 0.15	0.90 ± 0.10	1.75
<b>EPDX-ZH 000</b>	24	0.22	7 x 0.20	1.10 ± 0.10	2.90
<b>EPDX-ZH 00</b>	22	0.34	7 x 0.25	1.30 ± 0.10	4.35
<b>EPDX-ZH 26</b>	20	0.60	19 x 0.20	1.75 ± 0.15	7.60
<b>EPDX-ZH 27</b>	18	0.93	19 x 0.25	2.00 ± 0.15	11.05
<b>EPDX-ZH 28</b>	16	1.34	19 x 0.30	2.35 ± 0.15	15.85
<b>EPDX-ZH 29</b>	14	1.91	27 x 0.30	2.70 ± 0.15	22.00
<b>EPDX-ZH 100</b>	12	3.18	45 x 0.30	3.40 ± 0.20	36.00
<b>EPDX-ZH 140</b>	10	5.15	73 x 0.30	4.10 ± 0.20	56.50

## KY/EPDX-ZH, KY type- Halogen free unscreened hook-up wires - 750 volts

Nexans Reference	Conductor			Overall diameter mm	Average weight Kg/Km
	Gauge AWG	Cross section mm <sup>2</sup>	Construction n x Ø mm		
<b>EPDX-ZH 6</b>	24	0.22	7 x 0.20	1.70 ± 0.10	5.00
<b>EPDX-ZH 7</b>	22	0.38	12 x 0.20	2.15 ± 0.15	8.00
<b>EPDX-ZH 16</b>	20	0.60	19 x 0.20	2.35 ± 0.15	10.50
<b>EPDX-ZH 17</b>	18	1.00	32 x 0.20	2.65 ± 0.15	15.50
<b>EPDX-ZH 8</b>	16	1.34	19 x 0.30	2.85 ± 0.15	19.00
<b>EPDX-ZH 9</b>	14	1.91	27 x 0.30	3.20 ± 0.20	25.50
<b>EPDX-ZH 10</b>	12	3.18	45 x 0.30	4.00 ± 0.20	41.50
<b>EPDX-ZH 14</b>	10	5.15	73 x 0.30	4.60 ± 0.20	62.00



**150°C**



### Applications

Flexible and lightweight range of cables with FEP + superpolyamide insulation for use in bundles.

Abrasion resistance : medium  
They withstand most chemical fluids except for concentrated nitric acid.

**600 Volts RMS**

### Construction

#### 1- CONDUCTOR

Stranded tinned copper wires or stranded tinned copper alloy wires for the cross section area 0.21 mm<sup>2</sup>

#### 2- INSULATION

Fluoropolymer (FEP)

#### 3- OUTER JACKET

Superpolyamide (radial thickness: from 0.10 mm up to 0.15 mm)

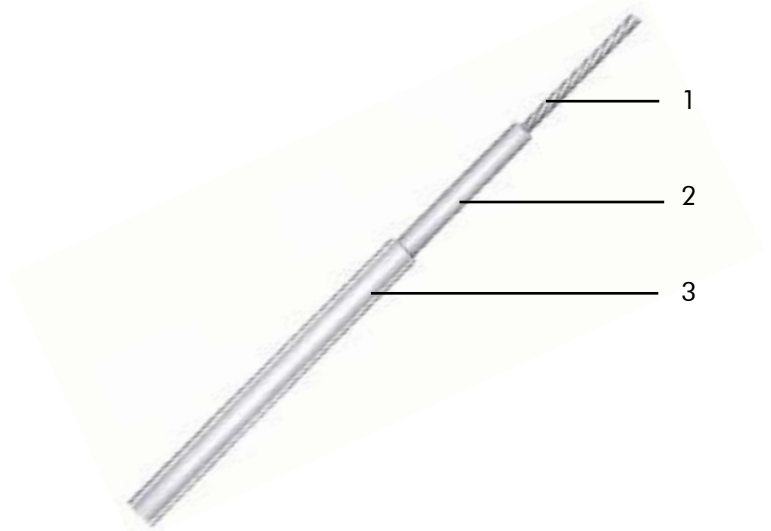

### Technical requirements and control conditions

Air 4524 specification of September 1965 - the 105°/135°C category, NF-L 52-120B BNAé specification of December 1971 - Lightweight cables.

### Colour coding

To AIR 0107 A of October 1961 and note N° 348/SIB distributed under N° 5927/STT/SIB (3.05.1961).

### Standards

To AIR 4524 and MIL-W 5086B/7A specifications.

These cables are approved by the Air Ministry under letters:

N° 34722 STA/EQ/E2 (18-4-69) for AWG 24

N° 41763 STA/EQ/E2 (12-11-68) for AWG 22 up to AWG 12

Registered at B.N.Ae:

N° 6412 420 A

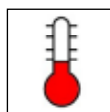

- 50°C to +140°C



Fire retardant  
(NF C 32-070/C1)



Flexible



RoHS

## 1806 - Unscreened hook-up wires

Nexans Reference			Conductor			Core		DC resist. at 20°C (maxi.) $\Omega / \text{km}$	Current rating A	Colour of cores
Type	Cross section	AWG	Construction n x $\varnothing$ mm	Nominal $\varnothing$ mm	Tensile strength daN.	Overall $\varnothing$ mm	Average weight Kg/Km			
<b>1806</b>	<b>0.21</b>	<b>24</b>	19 x 0.12 T.P.C All.	0.60	7	1.10 + 0.05	3.10	105.0	4	Light Blue
<b>1806</b>	<b>0.38</b>	<b>22</b>	12 x 0.20 T.P.C.	0.80	8	1.33 + 0.05	5.10	50.9	7	White
<b>1806</b>	<b>0.60</b>	<b>20</b>	19 x 0.20 T.P.C.	1.00	16	1.49 + 0.05	7.10	32.2	11	Light Blue
<b>1806</b>	<b>0.93</b>	<b>18</b>	19 x 0.25 T.P.C.	1.20	20	1.69 + 0.05	10.4	20.6	16	White
<b>1806</b>	<b>1.34</b>	<b>16</b>	19 x 0.30 T.P.C.	1.50	20	1.97 + 0.05	14.6	14.3	22	Light Blue
<b>1806</b>	<b>1.91</b>	<b>14</b>	27 x 0.30 T.P.C.	1.80	20	2.35 + 0.05	21.0	10.1	32	White
<b>1806</b>	<b>3.18</b>	<b>12</b>	45 x 0.30 T.P.C.	2.30	20	2.94 + 0.05	34.0	6.0	41	White

The shown current rating is valid for singles wires in air.

### Applications

Flexible and lightweight range of cables with FEP + superpolyamide insulation for use in bundles.

Abrasion resistance: medium  
They withstand most chemical fluids except for concentrated nitric acid.

**600 Volts RMS**

### Construction

#### BASE CORE 1806

#### 1- CONDUCTOR

Stranded tinned copper wires or stranded tinned copper alloy wires for the cross section area 0.21 mm

#### 2- INSULATION

Fluoropolymer (FEP)

#### 3- OUTER JACKET

Superpolyamide (radial thickness: from 0.10 mm up to 0.15 mm)

#### 806

#### 4- LAY UP

1 or several 1806 cores

#### 5- SCREEN

Tinned copper bra (Kr ≥ 62%)

#### 6- OUTER JACKET

Superpolyamide (radial thickness: about 0.20 mm)

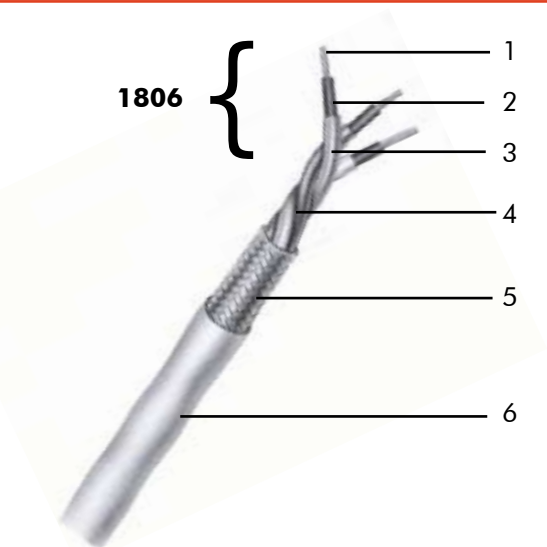

### Technical requirements and control conditions

Screen: to MIL.C. 7078C (August 1971) U.S. specification.

### Colour coding

To Air 0107 A (October 1961) and note N° 348/SIB distributed under N° 5927/STT/SIB (3-05-1961).

### Standards

To AIR 4524 and MIL-W 5086B/7A specifications.

These cables are approved by the Air Ministry under letters:

N° 34722 STA/EQ/E2 (18-4-69) for AWG 24

N° 41763 STA/EQ/E2 (12-11-68) for AWG 22 up to AWG 12

Registered at B.N.Ae : N° 6412 420 A

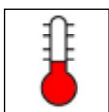

- 50°C to +140°C



Fire retardant  
(NF C 32-070/C1)



Flexible



EMI



RoHS

## 806 - Screened and jacketed hook-up wires and multicore cables

Nb of cores	Nexans Reference				BASE CORE : 1806			SERIE 806		
					Construction n x Ø mm	Overall Ø nomi- nal mm	Colour coding of cores	Colour of outer jacket	Overall Ø (maxi.) mm	Average weight Kg/Km
1	806	1	0.21	G 24	19 x 0.12 T.P.C All	1.10	Light blue	Light blue	2	6.3
	806	1	0.38	G 22	12 x 0.20 T.P.C.	1.33	White	White	2.3	10.8
	806	1	0.60	G 20	19 x 0.20 T.P.C.	1.49	Light blue	Light blue	2.5	13.3
	806	1	0.93	G 18	19 x 0.25 T.P.C.	1.69	White	White	2.7	17.3
	806	1	1.34	G 16	19 x 0.30 T.P.C.	1.97	Light blue	Light blue	3	22.5
	806	1	1.91	G 14	27 x 0.30 T.P.C.	2.35	White	White	3.3	29.9
	806	1	3.18	G 12	45 x 0.30 T.P.C.	2.94	White	White	4.2	47.0
2	806	2	0.21	G 24	19 x 0.12 T.P.C All	1.10	Light blue + Blue	Light blue	3.3	13.1
	806	2	0.38	G 22	12 x 0.20 T.P.C.	1.33	White + Blue	White	3.8	19.0
	806	2	0.60	G 20	19 x 0.20 T.P.C.	1.49	Light blue + Blue	Light blue	4.1	24.0
	806	2	0.93	G 18	19 x 0.25 T.P.C.	1.69	White + blue	White	4.5	33.7
	806	2	1.34	G 16	19 x 0.30 T.P.C.	1.97	Light blue + Blue	Light blue	5.2	44.1
	806	2	1.91	G 14	27 x 0.30 T.P.C.	2.35	White + Blue	White	5.9	59.0
	806	2	3.18	G 12	45 x 0.30 T.P.C.	2.94	White + Blue	White	7.7	94.0
3	806	3	0.21	G 24	19 x 0.12 T.P.C All	1.10	Light blue + Blue + Yellow	Light blue	3.5	17.5
	806	3	0.38	G 22	12 x 0.20 T.P.C.	1.33	White + Blue + Yellow	White	4	25.9
	806	3	0.60	G 20	19 x 0.20 T.P.C.	1.49	Light blue + Blue + Yellow	Light blue	4.4	35.0
	806	3	0.93	G 18	19 x 0.25 T.P.C.	1.69	White + Blue + Yellow	White	4.8	46.8
	806	3	1.34	G 16	19 x 0.30 T.P.C.	1.97	Light blue + Blue + Yellow	Light blue	5.5	61.9
	806	3	1.91	G 14	27 x 0.30 T.P.C.	2.35	White + Blue + Yellow	White	6.3	83.6
	806	3	3.18	G 12	45 x 0.30 T.P.C.	2.94	White + Blue + Yellow	White	8.2	134
4	806	4	0.21	G 24	19 x 0.12 T.P.C All	1.10	Light Blue + Blue + Yellow + Green	Light blue	3.7	21.6
	806	4	0.38	G 22	12 x 0.20 T.P.C.	1.33	White + Blue+ Yellow + Green	White	4.4	34.4
	806	4	0.60	G 20	19 x 0.20 T.P.C.	1.49	Light blue + Blue + Yellow + Green	Light blue	4.8	43.9
	806	4	0.93	G 18	19 x 0.25 T.P.C.	2.69	White + Blue + Yellow + Green	White	5.3	59.3
	806	4	1.34	G 16	19 x 0.30 T.P.C.	2.97	Light blue + Blue + Yellow + Green	Light blue	6	79.0
	806	4	1.91	G 14	27 x 0.30 T.P.C.	2.35	White + Blue + Yellow + Green	White	6.9	107.4
	806	4	3.18	G 12	45 x 0.30 T.P.C.	2.94	White + Blue + Yellow + Green	White	9.1	172.5

# KU

## Unscreened hook up wires, pairs and triples

### Applications

Internal wiring in electronic equipment.

600 volts

### Construction

#### BASE CORE KU 01

##### 1- CONDUCTOR

Stranded annealed tinned copper wires

##### 2- INSULATION

Ethylene and tetrafluorethylene copolymer (E.T.F.E)

#### KU 03 and KU 04

##### 3- LAY UP

2 or 3 base cores

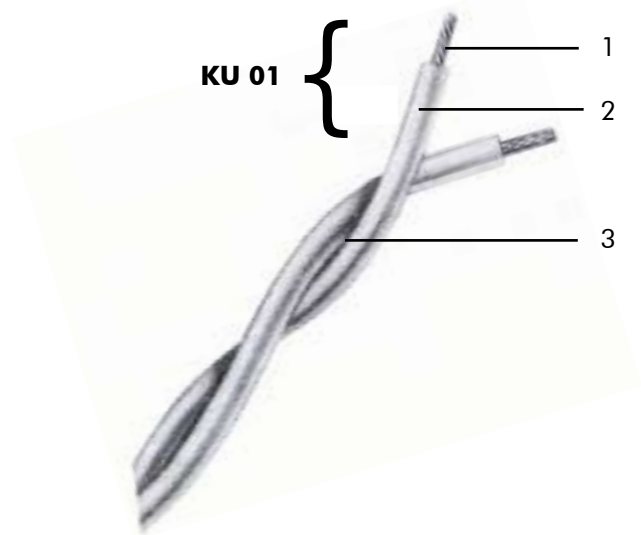

### Standards

NF C 93-524

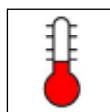

-55 °C to +150 °C



Flame and fire retardant  
(NF C 32-070/C1 & C2)



Flexible



RoHS

## KU - Unscreened hook up wires

NF C 93-524 and Nexans references	Gauge AWG	Cross section mm <sup>2</sup>	Construction n x Ø mm	Overall diameter		Average weight Kg / Km
				mini.	maxi.	
				mm		
<b>KU 01-30</b>	30	0.05	7 x 0.10	0.58	0.64	0.88
<b>KU 01-28</b>	28	0.09	7 x 0.13	0.64	0.70	1.25
<b>KU 01-26</b>	26	0.15	19 x 0.10	0.76	0.82	1.93
<b>KU 01-24</b>	24	0.25	19 x 0.13	0.86	0.92	2.88
<b>KU 01-22</b>	22	0.38	19 x 0.16	1.05	1.11	4.36
<b>KU 01-20</b>	20	0.60	19 x 0.20	1.47	1.53	6.98
<b>KU 01-18</b>	18	0.93	19 x 0.25	1.75	1.81	10.89
<b>KU 01-16</b>	16	1.34	19 x 0.30	1.93	2.03	14.79
<b>KU 01-14</b>	14	1.82	37 x 0.25	2.26	2.42	20.58
<b>KU 01-12</b>	12	3.00	37 x 0.32	2.79	2.95	32.95

## KU - Pairs and triples

Nb of cores	NF C 93-524 and Nexans references	BASE CORE					Overall Ø		Average weight Kg / Km	Colour coding of cores
		Type	Conductor			Nom Ø core mm	mini.	maxi.		
			Gauge AWG	Cross section mm <sup>2</sup>	Construction n x Ø mm		mm			
2	<b>KU 03 - 30</b>	KU 01 - 30	30	0.05	7 x 0.10	0.61	1.16	1.36	1.85	White Blue
	<b>KU 03 - 28</b>	KU 01 - 28	28	0.09	7 x 0.13	0.67	1.28	1.48	2.62	
	<b>KU 03 - 26</b>	KU 01 - 26	26	0.15	19 x 0.10	0.79	1.52	1.72	4.05	
	<b>KU 03 - 24</b>	KU 01 - 24	24	0.25	19 x 0.13	0.89	1.72	1.92	6.04	
	<b>KU 03 - 22</b>	KU 01 - 22	22	0.38	19 x 0.16	1.08	2.10	2.30	9.16	
	<b>KU 03 - 20</b>	KU 01 - 20	20	0.60	19 x 0.20	1.5	2.94	3.14	15.18	
	<b>KU 03 - 18</b>	KU 01 - 18	18	0.93	19 X 0.25	1.78	3.50	3.70	22.83	
	<b>KU 03 - 16</b>	KU 01 - 16	16	1.34	19 X 0.30	1.98	3.86	4.14	31.00	
	<b>KU 03 - 14</b>	KU 01 - 14	14	1.82	37 X 0.25	2.34	4.52	4.92	43.14	
<b>KU 03 - 12</b>	KU 01 - 12	12	3.00	37 X 0.32	2.87	5.58	5.98	69.06		
3	<b>KU 04 - 30</b>	KU 01 - 30	30	0.05	7 x 0.10	0.61	1.25	1.46	2.72	White Blue Orange
	<b>KU 04 - 28</b>	KU 01 - 28	28	0.09	7 x 0.13	0.67	1.38	1.58	3.86	
	<b>KU 04 - 26</b>	KU 01 - 26	26	0.15	19 x 0.10	0.79	1.63	1.85	5.97	
	<b>KU 04 - 24</b>	KU 01 - 24	24	0.25	19 x 0.13	0.89	1.85	2.06	8.90	
	<b>KU 04 - 22</b>	KU 01 - 22	22	0.38	19 x 0.16	1.08	2.26	2.47	13.50	
	<b>KU 04 - 20</b>	KU 01 - 20	20	0.60	19 x 0.20	1.5	3.16	3.38	22.37	
	<b>KU 04 - 18</b>	KU 01 - 18	18	0.93	19 X 0.25	1.78	3.76	3.98	33.65	
	<b>KU 04 - 16</b>	KU 01 - 16	16	1.34	19 X 0.30	1.98	4.15	4.45	45.70	
	<b>KU 04 - 14</b>	KU 01 - 14	14	1.82	37 X 0.25	2.34	4.86	5.29	63.59	
<b>KU 04 - 12</b>	KU 01 - 12	12	3.00	37 X 0.32	2.87	6.00	6.43	101.81		

# KU

## Screened and jacketed hook-up wires, pairs and triples

### Applications

Internal wiring in electronic equipment.

600 volts

### Construction

#### BASE CORE KU 01

##### 1- CONDUCTOR

Stranded annealed tinned copper wires

##### 2- INSULATION

Ethylene and tetrafluorethylene copolymer (E.T.F.E.)

#### KU 05 and KU 06

##### 3- SCREEN

Tinned copper braid

##### 4- OUTER JACKET

Ethylene and tetrafluorethylene copolymer (E.T.F.E.)

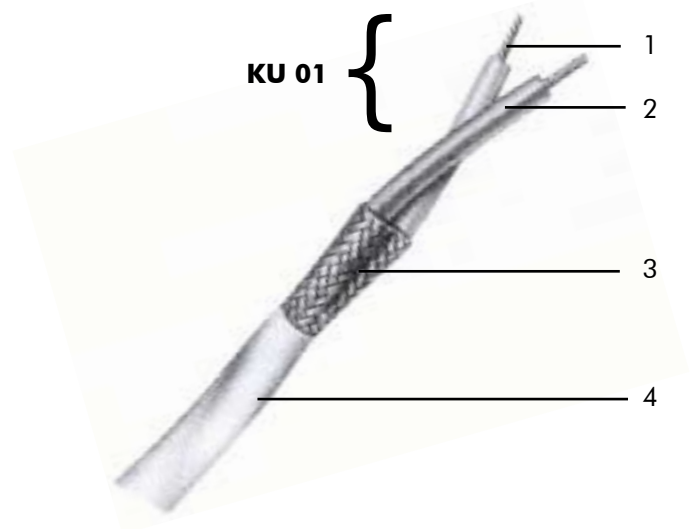

### Standards

NF C 93-524

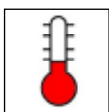

-55 °C to +150 °C



Flame and fire retardant  
(NF C 32-070/C1 & C2)



Flexible

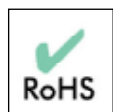

## KU - Screened and jacketed hook-up wires

Nb of cores	NF C 93-524 and Nexans references	BASE CORE					Overall diameter		Average weight Kg / Km
		Type	Conductor			Nom Ø core mm	mini.	maxi.	
			Gauge AWG	Cross section mm <sup>2</sup>	Construction n x Ø mm		mm		
1	<b>KU 02 - 30</b>	KU 01 - 30	30	0.05	7 x 0.10	0.61	1.35	1.43	4.10
	<b>KU 02 - 28</b>	KU 01 - 28	28	0.09	7 x 0.13	0.67	1.41	1.49	4.68
	<b>KU 02 - 26</b>	KU 01 - 26	26	0.15	19 x 0.10	0.79	1.51	1.59	5.70
	<b>KU 02 - 24</b>	KU 01 - 24	24	0.25	19 x 0.13	0.89	1.73	1.81	7.55
	<b>KU 02 - 22</b>	KU 01 - 22	22	0.38	19 x 0.16	1.08	1.96	2.06	10.02
	<b>KU 02 - 20</b>	KU 01 - 20	20	0.60	19 x 0.20	1.5	2.38	2.48	14.54
	<b>KU 02 - 18</b>	KU 01 - 18	18	0.93	19 X 0.25	1.78	2.76	2.88	20.72
	<b>KU 02 - 16</b>	KU 01 - 16	16	1.34	19 X 0.30	1.98	2.94	3.06	25.36
	<b>KU 02 - 14</b>	KU 01 - 14	14	1.82	37 X 0.25	2.34	3.26	3.40	32.48
<b>KU 02 - 12</b>	KU 01 - 12	12	3.00	37 X 0.32	2.87	3.75	3.95	47.06	

## KU - Screened and jacketed pairs and triples

Nb of cores	NF C 93-524 and Nexans references	BASE CORE					Overall Ø		Average weight Kg / Km	Colour coding of cores
		Type	Conductor			Nom Ø core mm	mini.	maxi.		
			Gauge AWG	Cross section mm <sup>2</sup>	Construction n x Ø mm		mm			
2	<b>KU 05 - 30</b>	KU 01 - 30	30	0.05	7 x 0.10	0.61	2.12	2.22	7.60	White Blue
	<b>KU 05 - 28</b>	KU 01 - 28	28	0.09	7 x 0.13	0.67	2.24	2.34	8.80	
	<b>KU 05 - 26</b>	KU 01 - 26	26	0.15	19 x 0.10	0.79	2.48	2.60	11.15	
	<b>KU 05 - 24</b>	KU 01 - 24	24	0.25	19 x 0.13	0.89	2.79	2.91	15.11	
	<b>KU 05 - 22</b>	KU 01 - 22	22	0.38	19 x 0.16	1.08	3.16	3.30	19.77	
	<b>KU 05 - 20</b>	KU 01 - 20	20	0.60	19 x 0.20	1.5	3.87	4.07	28.11	
	<b>KU 05 - 18</b>	KU 01 - 18	18	0.93	19 x 0.25	1.78	4.52	4.72	38.95	
	<b>KU 05 - 16</b>	KU 01 - 16	16	1.34	19 x 0.30	1.98	4.90	5.12	48.59	
	<b>KU 05 - 14</b>	KU 01 - 14	14	1.82	37 x 0.25	2.34	5.62	5.86	63.75	
<b>KU 05 - 12</b>	KU 01 - 12	12	3.00	37 x 0.32	2.87	6.67	6.97	94.29		
3	<b>KU 06 - 30</b>	KU 01 - 30	30	0.05	7 x 0.10	0.61	2.32	2.42	9.60	White Blue Orange
	<b>KU 06 - 28</b>	KU 01 - 28	28	0.09	7 x 0.13	0.67	2.36	2.46	10.70	
	<b>KU 06 - 26</b>	KU 01 - 26	26	0.15	19 x 0.10	0.79	2.70	2.82	14.89	
	<b>KU 06 - 24</b>	KU 01 - 24	24	0.25	19 x 0.13	0.89	2.83	2.95	18.09	
	<b>KU 06 - 22</b>	KU 01 - 22	22	0.38	19 x 0.16	1.08	3.23	3.37	24.36	
	<b>KU 06 - 20</b>	KU 01 - 20	20	0.60	19 x 0.20	1.5	4.13	4.33	37.00	
	<b>KU 06 - 18</b>	KU 01 - 18	18	0.93	19 x 0.25	1.78	4.72	4.94	50.70	
	<b>KU 06 - 16</b>	KU 01 - 16	16	1.34	19 x 0.30	1.98	5.18	5.40	64.90	
	<b>KU 06 - 14</b>	KU 01 - 14	14	1.82	37 x 0.25	2.34	5.96	6.22	86.37	
<b>KU 06 - 12</b>	KU 01 - 12	12	3.00	37 x 0.32	2.87	7.09	7.39	129.53		

## BRAID: Ø STRANDS

Reference	AWG	Ø mm	Reference	AWG	Ø mm
<b>KU 02</b>	From AWG 30 to AWG 20	0.10	<b>KU 05</b>	From AWG 24 to AWG 12	0.12
<b>KU 02</b>	From AWG 18 to AWG 12	0.12	<b>KU 06</b>	From AWG 30 to AWG 28	0.10
<b>KU 05</b>	From AWG 30 to AWG 26	0.10	<b>KU 06</b>	From AWG 24 to AWG 12	0.12



**200°C**



# KZ 04, KZ 05, KZ 06

Unscreened hook-up wires  
High temperature

## Applications

Internal wiring in electronic equipment.  
Aircrafts and satellites.  
Excellent chemical resistance.  
In order to increase the operating temperature of the cables up to 250°C, all KZ types can be produced with a nickel plated copper conductor on request.

From 250 to 1000 Volts

## Construction

### 1- CONDUCTOR

Stranded silvered copper wires

### 2- INSULATION

Extruded polytetrafluorethylene (P.T.F.E.)



## Standards

NF C 93-523

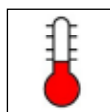

-55 °C to +200 °C



Fire retardant  
(NF C 32-070/C1)



Flexible



RoHS

## KZ - Unscreened hook-up wires, high temperature

NF C 93-523 and Nexans references	Gauge AWG	Cross section mm <sup>2</sup>	Construction n x Ø mm	Nom. Ø mm	D.C. resist. at 20°C maxi. Ohms / Km	Overall Ø		Maximum weight Kg / Km	Operating voltage Volts
						mini.	maxi.		
						mm			
<b>KZ 04 - 01</b>	32	0.035	7 x 0.08	0.24	546	0.48	0.58	0.95	250
<b>KZ 04 - 02</b>	30	0.055	7 x 0.10	0.30	349	0.56	0.66	1.3	
<b>KZ 04 - 03</b>	28	0.093	7 x 0.13	0.39	201	0.63	0.73	1.75	
<b>KZ 04 - 04</b>	26	0.14	7 x 0.16	0.48	132	0.74	0.84	2.4	
<b>KZ 04 - 05</b>	24	0.22	7 x 0.20	0.60	86	0.86	0.96	3.4	
<b>KZ 04 - 06</b>	22	0.34	7 x 0.25	0.75	54.4	1.01	1.11	5.0	
<b>KZ 04 - 07</b>	20	0.60	19 x 0.20	1.00	31.3	1.30	1.40	8.25	
<b>KZ 05 - 01</b>	32	0.035	7 x 0.08	0.24	546	0.63	0.84	1.65	600
<b>KZ 05 - 02</b>	30	0.055	7 x 0.10	0.30	349	0.71	0.91	2.1	
<b>KZ 05 - 03</b>	28	0.093	7 x 0.13	0.39	201	0.79	1.00	2.6	
<b>KZ 05 - 04</b>	26	0.14	7 x 0.16	0.48	132	0.89	1.10	3.4	
<b>KZ 05 - 05</b>	24	0.22	7 x 0.20	0.60	86	1.04	1.22	4.5	
<b>KZ 05 - 06</b>	22	0.34	7 x 0.25	0.75	54.4	1.17	1.37	6.2	
<b>KZ 05 - 07</b>	20	0.60	19 x 0.20	1.00	31.3	1.42	1.62	9.5	
<b>KZ 05 - 08</b>	18	0.93	19 x 0.25	1.25	20.5	1.67	1.92	14.1	
<b>KZ 05 - 09</b>	16	1.34	19 x 0.30	1.50	13.9	1.92	2.27	20.0	
<b>KZ 05 - 10</b>	14	1.91	27 x 0.30	1.85	10.0	2.30	2.66	27.0	
<b>KZ 05 - 11</b>	12	3.18	45 x 0.30	2.45	6.0	2.89	3.24	42.5	
<b>KZ 06 - 01</b>	32	0.035	7 x 0.08	0.24	546	0.88	1.09	2.6	1000
<b>KZ 06 - 02</b>	30	0.055	7 x 0.10	0.30	349	0.95	1.16	3.0	
<b>KZ 06 - 03</b>	28	0.093	7 x 0.13	0.39	201	1.04	1.24	3.7	
<b>KZ 06 - 04</b>	26	0.14	7 x 0.16	0.48	132	1.14	1.34	4.6	
<b>KZ 06 - 05</b>	24	0.22	7 x 0.20	0.60	86	1.27	1.47	5.75	
<b>KZ 06 - 06</b>	22	0.34	7 x 0.25	0.75	54.4	1.42	1.63	7.7	
<b>KZ 06 - 07</b>	20	0.60	19 x 0.20	1.00	31.3	1.66	1.86	11.0	
<b>KZ 06 - 08</b>	18	0.93	19 x 0.25	1.25	20.5	1.92	2.17	16.0	
<b>KZ 06 - 09</b>	16	1.34	19 x 0.30	1.50	13.9	2.10	2.41	21.1	
<b>KZ 06 - 10</b>	14	1.91	27 x 0.30	1.85	10.0	2.51	2.92	30.0	
<b>KZ 06 - 11</b>	12	3.18	45 x 0.30	2.45	6.0	3.14	3.55	47.5	

# KZ 55, KZ 57, KZ 59

## Screened and jacketed hook-up wires

### High temperature

#### Applications

Internal wiring in electronic equipment.  
Aircrafts and satellites.  
Excellent chemical resistance.  
In order to increase the operating temperature of the cables up to 250°C, all KZ types can be produced with a nickel plated copper conductor on request.

From 250 to 1000 Volts

#### Construction

##### 1- CONDUCTOR

Stranded silvered copper wires

##### 2- INSULATION

Extruded polytetrafluorethylene (P.T.F.E.)

##### 3- SCREEN

Silvered copper braid  
KZ 55 are reinforced with a polyimide tape.

##### 4- OUTER JACKET

Fluoropolymer (FEP) (radial thickness: 0.30 mm nominal)



#### Colour coding

- White core
- White outer jacket

#### Standards

NF C 93-523

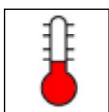

-55 °C to +200 °C



Fire retardant  
(NF C 32-070/C1)



Flexible

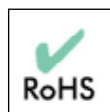

RoHS

## KZ - Screened and jacketed hook-up wires, high temperature

NF C 93-523 and Nexans references	BASE CORE					D.C. resist. at 20°C maxi. Ohms / Km	Braid nom. Ø of strands mm	Overall Ø		Maximum weight Kg / Km	Operating voltage Volts
	Type	Conductor						mini.	maxi.		
		Gauge AWG	Cross section mm <sup>2</sup>	Construction n x Ø mm	Nom. Ø mm						
<b>KZ 55-04</b>	KZ 04-04	26	0.14	7 x 0.16	0.48	132	0.10	1.85	2.05	8.11	<b>250</b>
<b>KZ 55-05</b>	KZ 04-05	24	0.22	7 x 0.20	0.60	86	0.10	1.97	2.17	9.66	
<b>KZ 55-06</b>	KZ 04-06	22	0.34	7 x 0.25	0.75	54.4	0.10	2.12	2.32	11.90	
<b>KZ 55-07</b>	KZ 04-07	20	0.60	19 x 0.20	1.00	31.3	0.10	2.40	2.60	16.50	
<b>KZ 57-01</b>	KZ 05-01	32	0.035	7 x 0.08	0.24	546	0.10	1.72	1.97	6.72	<b>600</b>
<b>KZ 57-02</b>	KZ 05-02	30	0.055	7 x 0.10	0.30	349	0.10	1.79	2.04	7.49	
<b>KZ 57-03</b>	KZ 05-03	28	0.093	7 x 0.13	0.39	201	0.10	1.88	2.13	8.39	
<b>KZ 57-04</b>	KZ 05-04	26	0.14	7 x 0.16	0.48	132	0.10	1.98	2.23	9.63	
<b>KZ 57-05</b>	KZ 05-05	24	0.22	7 x 0.20	0.60	86	0.10	2.11	2.36	11.30	
<b>KZ 57-06</b>	KZ 05-06	22	0.34	7 x 0.25	0.75	54.4	0.10	2.25	2.50	13.60	
<b>KZ 57-07</b>	KZ 05-07	20	0.60	19 x 0.20	1.00	31.3	0.13	2.65	2.90	20.00	
<b>KZ 57-08</b>	KZ 05-08	18	0.93	19 x 0.25	1.25	20.5	0.13	2.93	3.18	26.10	
<b>KZ 57-09</b>	KZ 05-09	16	1.34	19 x 0.30	1.50	13.9	0.13	3.23	3.53	33.50	
<b>KZ 57-10</b>	KZ 05-10	14	1.91	27 x 0.30	1.85	10.0	0.13	3.61	3.91	42.60	
<b>KZ 57-11</b>	KZ 05-11	12	3.18	45 x 0.30	2.45	6.0	0.13	4.19	4.49	61.10	
<b>KZ 59-01</b>	KZ 06-01	32	0.035	7 x 0.08	0.24	546	0.10	1.97	2.22	8.79	<b>1000</b>
<b>KZ 59-02</b>	KZ 06-02	30	0.055	7 x 0.10	0.30	349	0.10	2.03	2.28	9.45	
<b>KZ 59-03</b>	KZ 06-03	28	0.093	7 x 0.13	0.39	201	0.10	2.12	2.37	10.6	
<b>KZ 59-04</b>	KZ 06-04	26	0.14	7 x 0.16	0.48	132	0.10	2.22	2.47	11.9	
<b>KZ 59-05</b>	KZ 06-05	24	0.22	7 x 0.20	0.60	86	0.10	2.35	2.60	13.6	
<b>KZ 59-06</b>	KZ 06-06	22	0.34	7 x 0.25	0.75	54.4	0.13	2.65	2.90	18.2	
<b>KZ 59-07</b>	KZ 06-07	20	0.60	19 x 0.20	1.00	31.3	0.13	2.89	3.14	22.7	
<b>KZ 59-08</b>	KZ 06-08	18	0.93	19 x 0.25	1.25	20.5	0.13	3.18	3.43	29.2	
<b>KZ 59-09</b>	KZ 06-09	16	1.34	19 x 0.30	1.50	13.9	0.13	3.38	3.68	35.4	
<b>KZ 59-10</b>	KZ 06-10	14	1.91	27 x 0.30	1.85	10.0	0.13	3.84	4.19	46.8	
<b>KZ 59-11</b>	KZ 06-11	12	3.18	45 x 0.30	2.45	6.0	0.13	4.65	5.00	70.4	

# KZ 67, KZ 69, KZ 71

Screened and jacketed pairs  
High temperature

## Applications

Internal wiring in electronic equipment.  
Aircrafts and satellites.

From 250 to 1000 Volts

## Construction

### 1- CONDUCTOR

Stranded silvered copper wires

### 2- INSULATION

Extruded polytetrafluorethylene (P.T.F.E.)

### 3- SCREEN

Silvered copper braid  
KZ 67 are reinforced with a polyimide tape.

### 4- OUTER JACKET

Fluoropolymer (FEP) (radial thickness: 0.30 mm nominal)

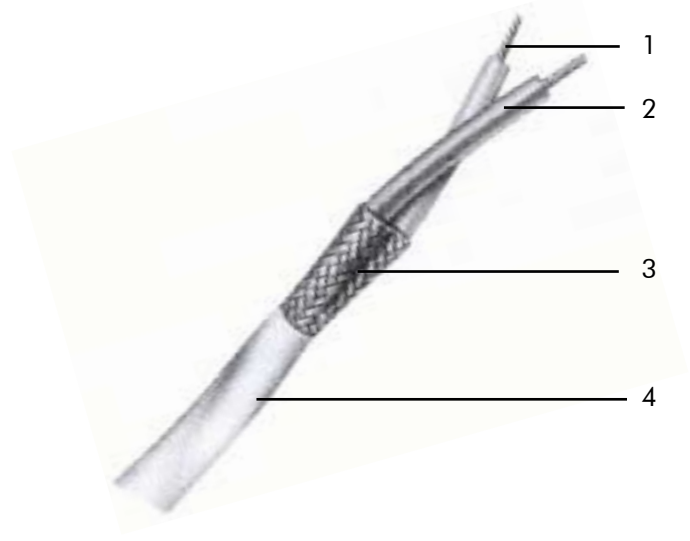

## Colour coding

- Cores : white + light blue
- Outer jacket : white

## Standards

NF C 93-523

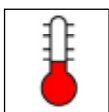

-55 °C to +200 °C



Fire retardant  
(NF C 32-070/C1)



Flexible

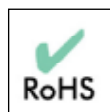

RoHS

## KZ - Screened and jacketed pairs, high temperature

NF C 93-523 and Nexans references	BASE CORE					D.C. resist. at 20°C max. (Ohms/ Km)	Braid nom Ø. of strands mm	Overall Ø		Average weight Kg / Km	Operating voltage Volts
	Type	Conductor						mini.	maxi.		
		Gauge AWG	Cross section mm <sup>2</sup>	Construction n x Ø mm	Ø Nom. mm			mm			
<b>KZ 67-01</b>	KZ 04-01	32	0.035	7 x 0.08	0.24	573	0.10	2.11	2.36	8.03	250
<b>KZ 67-02</b>	KZ 04-02	30	0.055	7 x 0.10	0.30	366	0.10	2.27	2.52	9.35	
<b>KZ 67-03</b>	KZ 04-03	28	0.093	7 x 0.13	0.39	211	0.10	2.41	2.62	10.8	
<b>KZ 67-04</b>	KZ 04-04	26	0.14	7 x 0.16	0.48	138	0.10	2.63	2.88	13.0	
<b>KZ 67-05</b>	KZ 04-05	24	0.22	7 x 0.20	0.60	90	0.13	3.02	3.27	17.9	
<b>KZ 67-06</b>	KZ 04-06	22	0.34	7 x 0.25	0.75	57	0.13	3.32	3.57	22.5	
<b>KZ 67-07</b>	KZ 04-07	20	0.60	19 x 0.20	1.00	33	0.13	3.90	4.15	31.7	
<b>KZ 69-01</b>	KZ 05-01	32	0.035	7 x 0.08	0.24	573	0.10	2.46	2.71	10.6	600
<b>KZ 69-02</b>	KZ 05-02	30	0.055	7 x 0.10	0.30	366	0.10	2.60	2.85	12.0	
<b>KZ 69-03</b>	KZ 05-03	28	0.093	7 x 0.13	0.39	211	0.10	2.78	3.03	13.7	
<b>KZ 69-04</b>	KZ 05-04	26	0.14	7 x 0.16	0.48	138	0.13	3.13	3.38	18.1	
<b>KZ 69-05</b>	KZ 05-05	24	0.22	7 x 0.20	0.60	90	0.13	3.39	3.64	21.5	
<b>KZ 69-06</b>	KZ 05-06	22	0.34	7 x 0.25	0.75	57	0.13	3.67	3.92	26.2	
<b>KZ 69-07</b>	KZ 05-07	20	0.60	19 x 0.20	1.00	33	0.13	4.17	4.42	35.1	
<b>KZ 69-08</b>	KZ 05-08	18	0.93	19 x 0.25	1.25	21.5	0.13	4.73	5.08	46.9	
<b>KZ 69-09</b>	KZ 05-09	16	1.34	19 x 0.30	1.50	14.6	0.13	5.51	5.86	64.4	
<b>KZ 69-10</b>	KZ 05-10	14	1.91	27 x 0.30	1.85	10.5	0.13	6.27	6.62	82.4	
<b>KZ 69-11</b>	KZ 05-11	12	3.18	45 x 0.30	2.45	6.3	0.13	7.43	7.78	120.0	
<b>KZ 71-01</b>	KZ 06-01	32	0.035	7 x 0.08	0.24	573	0.13	3.11	3.36	16.4	1000
<b>KZ 71-02</b>	KZ 06-02	30	0.055	7 x 0.10	0.30	366	0.13	3.23	3.48	17.7	
<b>KZ 71-03</b>	KZ 06-03	28	0.093	7 x 0.13	0.39	211	0.13	3.41	3.66	19.9	
<b>KZ 71-04</b>	KZ 06-04	26	0.14	7 x 0.16	0.48	138	0.13	3.61	3.86	22.6	
<b>KZ 71-05</b>	KZ 06-05	24	0.22	7 x 0.20	0.60	90	0.13	3.87	4.12	26.1	
<b>KZ 71-06</b>	KZ 06-06	22	0.34	7 x 0.25	0.75	57	0.13	4.17	4.42	31.4	
<b>KZ 71-07</b>	KZ 06-07	20	0.60	19 x 0.20	1.00	33	0.13	4.65	4.90	40.2	
<b>KZ 71-08</b>	KZ 06-08	18	0.93	19 x 0.25	1.25	21.5	0.13	5.39	5.64	55.6	
<b>KZ 71-09</b>	KZ 06-09	16	1.34	19 x 0.30	1.50	14.6	0.13	5.81	6.16	68.1	
<b>KZ 71-10</b>	KZ 06-10	14	1.91	27 x 0.30	1.85	10.5	0.13	6.73	7.08	90.7	
<b>KZ 71-11</b>	KZ 06-11	12	3.18	45 x 0.30	2.45	6.3	0.13	7.99	8.34	133	

# KZ 79, KZ 81, KZ 83

Screened and jacketed triples  
High temperature

## Applications

Internal wiring in electronic equipment.  
Aircrafts and satellites.

From 250 to 1000 Volts

## Construction

### 1- CONDUCTOR

Stranded silvered copper wires

### 2- INSULATION

Extruded polytetrafluorethylene (P.T.F.E.)

### 3- SCREEN

Silvered copper braid  
KZ 79 are reinforced with a polyimide tape.

### 4- OUTER JACKET

Fluoropolymer (FEP) (radial thickness: 0.30 mm nominal)

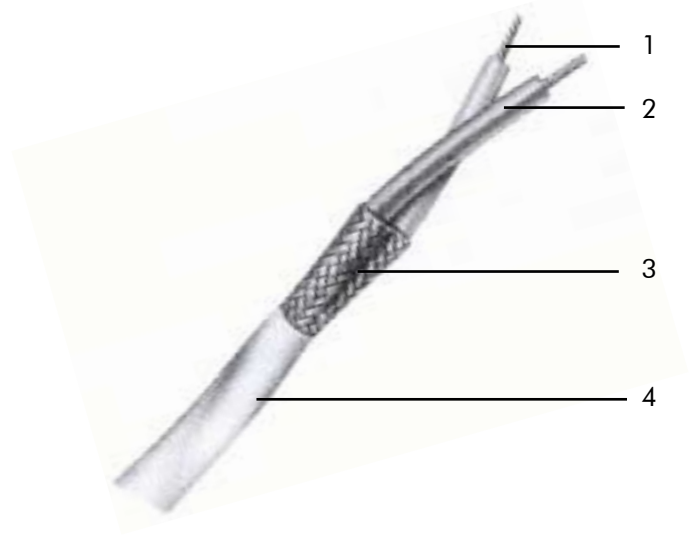

## Colour coding

- Cores : white + light blue + orange
- Outer jacket : white

## Standards

NF C 93-523

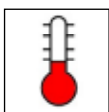

-55 °C to +200 °C



Fire retardant  
(NF C 32-070/C1)



Flexible

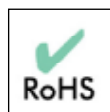

RoHS

## KZ - Screened and jacketed triples, high temperature

NF C 93-523 and Nexans references	BASE CORE					D.C. resist. at 20°C maxi. Ohms/Km	Braid nom Ø of strands mm mini.	Overall Ø		Average weight Kg / Km	Operating voltage Volts
	Type	Conductor						mini.	maxi.		
		Gauge AWG	Cross section mm <sup>2</sup>	Construction n x Ø mm	Ø Nom. mm			mm			
<b>KZ 79-01</b>	KZ 04-01	32	0.035	7 x 0.08	0.24	573	0.10	2.19	2.44	9.85	250
<b>KZ 79-02</b>	KZ 04-02	30	0.055	7 x 0.10	0.30	366	0.10	2.36	2.61	11.7	
<b>KZ 79-03</b>	KZ 04-03	28	0.093	7 x 0.13	0.39	211	0.10	2.51	2.76	13.7	
<b>KZ 79-04</b>	KZ 04-04	26	0.14	7 x 0.16	0.48	138	0.13	2.90	3.15	18.7	
<b>KZ 79-05</b>	KZ 04-05	24	0.22	7 x 0.20	0.60	90	0.13	3.15	3.40	23.1	
<b>KZ 79-06</b>	KZ 04-06	22	0.34	7 x 0.25	0.75	57	0.13	3.48	3.73	29.6	
<b>KZ 79-07</b>	KZ 04-07	20	0.60	19 x 0.20	1.00	33	0.13	4.10	4.35	42.7	
<b>KZ 81-01</b>	KZ 05-01	32	0.035	7 x 0.08	0.24	573	0.10	2.57	2.82	13.4	600
<b>KZ 81-02</b>	KZ 05-02	30	0.055	7 x 0.10	0.30	366	0.13	2.87	3.12	17.4	
<b>KZ 81-03</b>	KZ 05-03	28	0.093	7 x 0.13	0.39	211	0.13	3.07	3.32	19.9	
<b>KZ 81-04</b>	KZ 05-04	26	0.14	7 x 0.16	0.48	138	0.13	3.28	3.53	23.4	
<b>KZ 81-05</b>	KZ 05-05	24	0.22	7 x 0.20	0.60	90	0.13	3.56	3.81	28.2	
<b>KZ 81-06</b>	KZ 05-06	22	0.34	7 x 0.25	0.75	57	0.13	3.86	4.11	34.8	
<b>KZ 81-07</b>	KZ 05-07	20	0.60	19 x 0.20	1.00	33	0.13	4.40	4.65	47.6	
<b>KZ 81-08</b>	KZ 05-08	18	0.93	19 x 0.25	1.25	21.5	0.13	5.18	5.53	67.5	
<b>KZ 81-09</b>	KZ 05-09	16	1.34	19 x 0.30	1.50	14.6	0.13	5.83	6.18	89.1	
<b>KZ 81-10</b>	KZ 05-10	14	1.91	27 x 0.30	1.85	10.5	0.13	6.64	7.00	115	
<b>KZ 81-11</b>	KZ 05-11	12	3.18	45 x 0.30	2.45	6.3	0.13	7.89	8.24	169	
<b>KZ 83-01</b>	KZ 06-01	32	0.035	7 x 0.08	0.24	573	0.13	3.26	3.51	20.9	1000
<b>KZ 83-02</b>	KZ 06-02	30	0.055	7 x 0.10	0.30	366	0.13	3.39	3.64	22.7	
<b>KZ 83-03</b>	KZ 06-03	28	0.093	7 x 0.13	0.39	211	0.13	3.58	3.83	25.8	
<b>KZ 83-04</b>	KZ 06-04	26	0.14	7 x 0.16	0.48	138	0.13	3.80	4.05	29.6	
<b>KZ 83-05</b>	KZ 06-05	24	0.22	7 x 0.20	0.60	90	0.13	4.08	4.33	34.5	
<b>KZ 83-06</b>	KZ 06-06	22	0.34	7 x 0.25	0.75	57	0.13	4.40	4.65	42.1	
<b>KZ 83-07</b>	KZ 06-07	20	0.60	19 x 0.20	1.00	33	0.13	5.09	5.34	57.6	
<b>KZ 83-08</b>	KZ 06-08	18	0.93	19 x 0.25	1.25	21.5	0.13	5.70	6.15	76.2	
<b>KZ 83-09</b>	KZ 06-09	16	1.34	19 x 0.30	1.50	14.6	0.13	6.15	6.60	94.8	
<b>KZ 83-10</b>	KZ 06-10	14	1.91	27 x 0.30	1.85	10.5	0.13	7.14	7.59	127	
<b>KZ 83-11</b>	KZ 06-11	12	3.18	45 x 0.30	2.45	6.3	0.13	8.49	8.94	188	

# ETF, EF & EEF

Unscreened hook-up wires  
High temperature

## Applications

Internal wiring in electronic equipment.  
Aircrafts and satellites.  
Excellent chemical resistance.  
In order to increase the operating temperature of the cables up to 250°C, all KZ types can be produced with a nickel plated copper conductor on request.

From 250 to 1000 Volts

## Construction

### 1- CONDUCTOR

Stranded silvered copper wires

### 2- INSULATION

Extruded polytetrafluorethylene (P.T.F.E.)



## Standards

To MIL W 16878/4 (EF) ,  
16878/5 (EEF), 16878/6 (ETF)  
U.S. specification

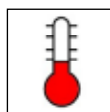

-55 °C to +200 °C



Fire retardant  
(NF C 32-070/C1)



Flexible



RoHS

## ETF, EF & EEF - Unscreened hook-up wires, high temperature

Nexans Reference	Gauge AWG	Cross section mm <sup>2</sup>	Construction n x Ø mm	Nom. Ø mm	Overall diameter		Operating voltage Volts
					mini.	maxi.	
					mm		
<b>ETF 32-07</b>	32	0.035	7 x 0.079	0.24	0.50	0.61	<b>250</b>
<b>ETF 30-07</b>	30	0.057	7 x 0.102	0.30	0.56	0.66	
<b>ETF 30-19</b>	30	0.054	19 x 0.06	0.30	0.56	0.66	
<b>ETF 28-07</b>	28	0.089	7 x 0.127	0.39	0.63	0.74	
<b>ETF 28-19</b>	28	0.093	19 x 0.079	0.39	0.63	0.74	
<b>ETF 26-07</b>	26	0.14	7 x 0.16	0.48	0.74	0.84	
<b>ETF 26-19</b>	26	0.15	19 x 0.102	0.48	0.74	0.84	
<b>ETF 24-07</b>	24	0.22	7 x 0.203	0.59	0.86	0.96	
<b>ETF 24-19</b>	24	0.24	19 x 0.127	0.63	0.86	0.96	
<b>ETF 22-07</b>	22	0.36	7 x 0.254	0.74	1.01	1.12	
<b>ETF 22-19</b>	22	0.38	19 x 0.16	0.78	1.01	1.12	
<b>ETF 20-07</b>	20	0.56	7 x 0.32	0.95	1.22	1.32	
<b>ETF 20-19</b>	20	0.61	19 x 0.203	0.97	1.22	1.32	
<b>EF 32-07</b>	32	0.035	7 x 0.079	0.24	0.66	0.86	<b>600</b>
<b>EF 30-07</b>	30	0.057	7 x 0.102	0.30	0.71	0.91	
<b>EF 30-19</b>	30	0.054	19 x 0.06	0.34	0.71	0.91	
<b>EF 28-07</b>	28	0.089	7 x 0.127	0.39	0.79	1.00	
<b>EF 28-19</b>	28	0.093	19 x 0.079	0.39	0.79	1.00	
<b>EF 26-07</b>	26	0.14	7 x 0.16	0.48	0.89	1.10	
<b>EF 26-19</b>	26	0.15	19 x 0.102	0.48	0.89	1.10	
<b>EF 24-07</b>	24	0.22	7 x 0.203	0.59	1.02	1.22	
<b>EF 24-19</b>	24	0.24	19 x 0.127	0.63	1.02	1.22	
<b>EF 22-07</b>	22	0.36	7 x 0.254	0.74	1.17	1.37	
<b>EF 22-19</b>	22	0.38	19 x 0.16	0.78	1.17	1.37	
<b>EF 20-07</b>	20	0.56	7 x 0.32	0.95	1.37	1.57	
<b>EF 20-19</b>	20	0.61	19 x 0.203	0.97	1.37	1.57	
<b>EF 18-07</b>	18	0.89	7 x 0.404	1.19	1.63	1.88	
<b>EF 18-19</b>	18	0.96	19 x 0.254	1.21	1.63	1.88	
<b>EF 16-19</b>	16	1.23	19 x 0.287	1.45	1.85	2.21	
<b>EEF 32-07</b>	32	0.035	7 x 0.079	0.24	0.91	1.12	<b>1000</b>
<b>EEF 30-07</b>	30	0.057	7 x 0.102	0.30	0.97	1.17	
<b>EEF 30-19</b>	30	0.054	19 x 0.06	0.34	0.97	1.17	
<b>EEF 28-07</b>	28	0.089	7 x 0.127	0.39	1.04	1.24	
<b>EEF 28-19</b>	28	0.093	19 x 0.079	0.39	1.04	1.24	
<b>EEF 26-07</b>	26	0.14	7 x 0.16	0.48	1.14	1.35	
<b>EEF 26-19</b>	26	0.15	19 x 0.102	0.48	1.14	1.35	
<b>EEF 24-07</b>	24	0.22	7 x 0.203	0.59	1.27	1.47	
<b>EEF 24-19</b>	24	0.24	19 x 0.127	0.63	1.27	1.47	
<b>EEF 22-07</b>	22	0.36	7 x 0.254	0.74	1.42	1.63	
<b>EEF 22-19</b>	22	0.38	19 x 0.16	0.78	1.42	1.63	
<b>EEF 20-07</b>	20	0.56	7 x 0.32	0.95	1.63	1.83	
<b>EEF 20-19</b>	20	0.61	19 x 0.203	0.97	1.63	1.83	
<b>EEF 18-07</b>	18	0.89	7 x 0.404	1.19	1.88	2.13	
<b>EEF 18-19</b>	18	0.96	19 x 0.254	1.21	1.88	2.13	
<b>EEF 16-19</b>	16	1.23	19 x 0.287	1.45	2.10	2.41	



**250°C**



# 1900 A

**Flexible cables  
for high ambient temperatures  
Light weight cables**

## Applications

These cables may be used at high ambient temperatures, up to 280°C at peak.

They can be used in bundles.

They are non-flammable.

They withstand most chemical fluids.

**600 Volts RMS**

## Construction

### 1- CONDUCTOR

Stranded nickel plated copper or nickel plated copper alloy wires for the cross section area 0.21 mm<sup>2</sup> (high mechanical resistance)

### 2- INSULATION

PTFE

- extruded (from 0.21 to 1.34 mm<sup>2</sup>),
- wrapped and fused (1.91 and 3.18 mm<sup>2</sup>)



## Technical requirements and control conditions

Air 4524 specification of September 1965 - the 250°/280°C category,

NF-L 52-125 A BNAé specification of December 1971

- Category C - Lightweight cables.

## Standards

To AIR 4524, B.N.Aé

These cables are approved by the Air Ministry under letters:

N°31951 STA/EQ/E2 (02-67) for AWG 24

N°40204 STA/EQ/E2 (10-63) for AWG 20 up to AWG 12

Registered at B.N.Ae: :

N° 6418 430 B

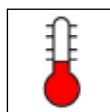

-50 °C à +250 °C



AIR 4524

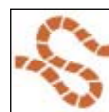

Flexible



RoHS

## ■ 1900 A - Flexible cables for high ambient temperatures, light weight cables

Nexans reference			Conductor			Core			Electrical Values	
Type	Cross section	US AWG	Construction	nominal Ø	Tensile strength	Overall diameter mm		Average weight Kg/Km	DC resist. at 20°C Ω / km	Current rating
			n x Ø mm	mm	daN	Min.	Max.	Max.	Max.	A
<b>1900 A</b>	0.21	24	19 x 0.12 N. P. All.	0.59	7.3	1.15	1.25	4.18	112.3	4
<b>1900 A</b>	0.38	22	12 x 0.20 N.P.C.	0.78	8.0	1.35	1.50	6.64	54.50	7
<b>1900 A</b>	0.60	20	19 x 0.20 N.P.C.	0.98	16.0	1.55	1.70	9.32	34.40	11
<b>1900 A</b>	0.93	18	19 x 0.25 N.P.C.	1.22	> 20.0	1.80	2.00	13.53	22.00	16
<b>1900 A</b>	1.34	16	19 x 0.30 N.P.C.	1.47	> 20.0	2.10	2.30	18.39	15.30	22
<b>1900 A</b>	1.91	14	27 x 0.30 N.P.C.	1.74	> 20.0	-	2.60	24.37	10.80	32
<b>1900 A</b>	3.18	12	45 x 0.30 N.P.C.	2.25	> 20.0	-	3.30	38.14	6.40	41

N.P.All. = nickel plated annealed copper alloy – N.P.C. = nickel plated annealed electrolytic copper  
 The currents shown are valid for single wires in air.

# 2100

## Flexible cables for high ambient temperature

### Applications

These cables are designed for use at high ambient temperatures up to 280°C at peak. Excellent flame resistance, non-flammable, they withstand most solvents.

600 volts RMS

### Construction

#### 1- CONDUCTOR

Stranded nickel plated copper, thin wrapped PTFE layer

#### 2- INSULATION

Polyimide

#### 3- OUTER JACKET

##### a) From 0.38 to 1.34 mm<sup>2</sup>:

Extruded PTFE sheath (high abrasion resistance)

##### b) From 1.91 mm<sup>2</sup> :

Composite glass fibre + PTFE + wrapped and sintered PTFE sheath.

Cross sections from 0.38 to 1.34 mm<sup>2</sup>



Cross sections from 1.91 mm<sup>2</sup>

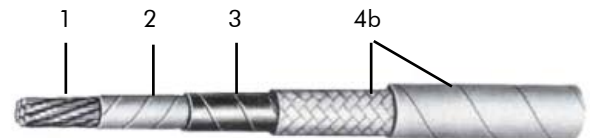

### Technical requirements and control conditions

Air4524 Specification of September 1965 - Category 250/280°C, NFL 52-125A French Draft Specification - Category C, of July 1978 - Standard cables.

### Interchangeability

MIL-W-22759 D Specification - Index 8 A of June 1973.

### Colour coding

According to AIR0107 (10/1961).

### Standards

To AIR 4524, B.N.Aé, MIL-W-22759 D & B.M.S. 13-58  
These cables are approved by the Air Ministry under letters : N°42707 STA/EQ/E2 (03-12-68)  
Registered at the B.N.Aé : N° 6418 401

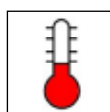

-50 °C to +250 °C



AIR 4524



Flexible



RoHS

## 2100 - Flexible cables for high ambient temperature

Nexans Reference			Conductor		Core			Electrical Values	
			Construction	Nominal Ø	Overall Ø	Weight		D.C. Resistance at 20°C (maxi.)	Current rating
Type	Cross section	Gauge AWG	n x Ø mm	mm	mm	nomi. g/m	maxi. g/m	Ω / km	A
<b>2100</b>	<b>0.38</b>	<b>22</b>	12 x 0.20	0.85	1.90 ± 0.10	8.6	9.3	54.50	7
<b>2100</b>	<b>0.60</b>	<b>20</b>	19 x 0.20	1.00	2.20 ± 0.10	12.1	12.4	34.40	11
<b>2100</b>	<b>0.93</b>	<b>18</b>	19 x 0.25	1.25	2.40 ± 0.10	15.8	17	22.00	16
<b>2100</b>	<b>1.34</b>	<b>16</b>	19 x 0.30	1.50	2.70 ± 0.10	19.6	20	15.30	22
<b>2100</b>	<b>1.91</b>	<b>14</b>	27 x 0.30	1.85	2.95 ± 0.10	26.1	27	10.80	32
<b>2100</b>	<b>3.18</b>	<b>12</b>	45 x 0.30	2.40	3.60 ± 0.15	40.8	16.5	6.50	41
<b>2100</b>	<b>5.15</b>	<b>10</b>	73 x 0.30	3.10	4.20 ± 0.20	60.4	65	3.40	55
<b>2100</b>	<b>8.98</b>	<b>8</b>	127 x 0.30	4.00	5.30 ± 0.20	102	108	2.30	75
<b>2100</b>	<b>13.40</b>	<b>6</b>	27 x 7 x 0.30	5.10	7.00 ± 0.30	158	160	1.60	100
<b>2100</b>	<b>21.80</b>	<b>4</b>	37 x 12 x 0.25	6.60	9.00 ± 0.30	237	245	0.97	135
<b>2100</b>	<b>34.50</b>	<b>2</b>	37 x 19 x 0.25	8.10	10.60 ± 0.30	391	396	0.61	181
<b>2100</b>	<b>41.80</b>	<b>1</b>	37 x 23 x 0.25	9.80	11.80 ± 0.30	460	470	0.50	211
<b>2100</b>	<b>52.70</b>	<b>0</b>	37 x 29 x 0.25	10.80	13.10 ± 0.30	580	600	0.40	245
<b>2100</b>	<b>67.20</b>	<b>00</b>	37 x 37 x 0.25	12.40	14.20 ± 0.30	736	750	0.31	283

The currents shown are valid for single wires in air.

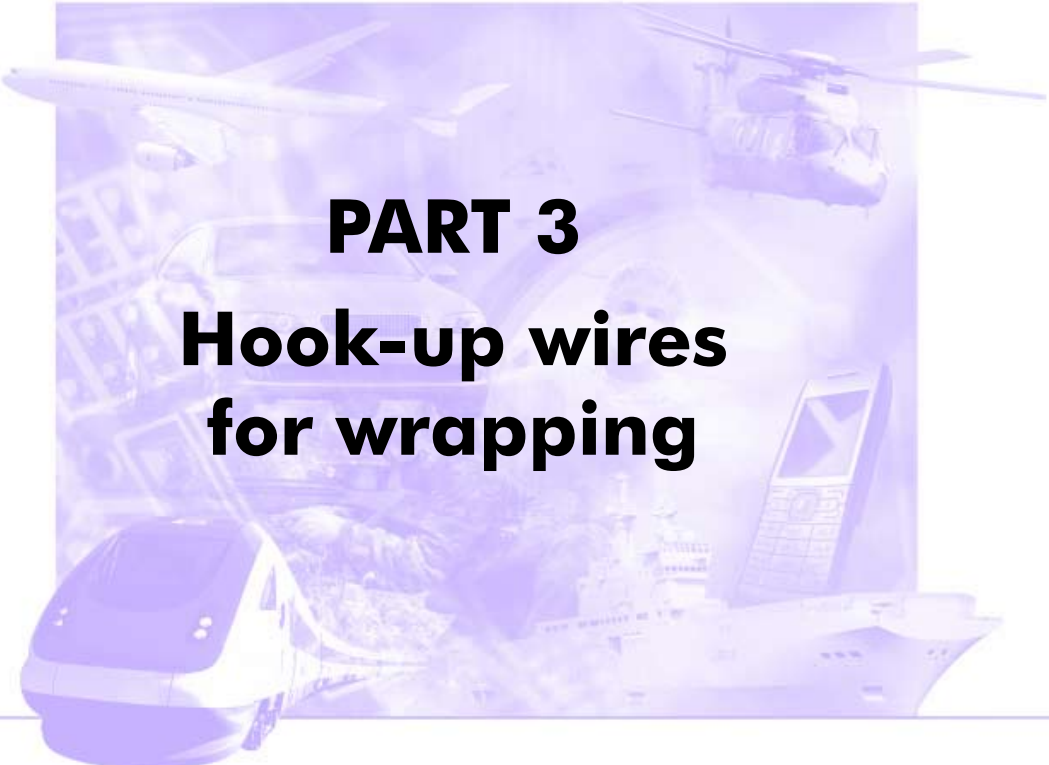

**PART 3**  
**Hook-up wires**  
**for wrapping**



# WRAPPING

## Hook-up wires for wire-wrapping

### Applications

These wires are designed for wire-wrapping connection consisting in winding a wire helically around a metallic terminal without any soldering operation.  
Fast and robust connections.

350 volts

### Construction

#### 1- CONDUCTOR

Solid silvered copper wires

#### 2- INSULATION

Polyvinyl chloride (PVC) or ethylene and tetrafluorethylene copolymer (E.T.F.E.) or polytetrafluorethylene (P.T.F.E.)

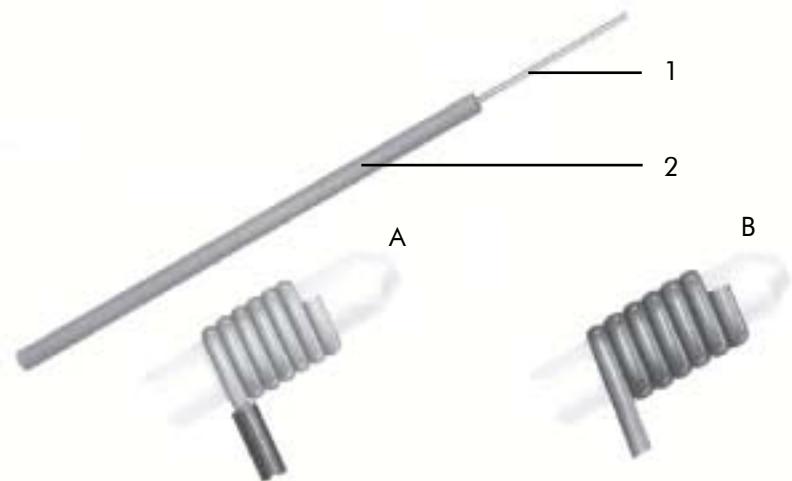

### Wire-wrapping procedure

Method **A** : conductor only wrapped around pin.

Method **B** : conductor with insulation wrapped around pin (better elasticity of connection).

### Standards

NF C 93-522

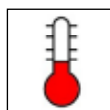

PVC : -40 °C to +85 °C  
ETFE : -60 °C to +150 °C  
PTFE : -90 °C to +200 °C



PVC : NF C 32-070/C1  
ETFE : NF C 32-070/C1  
PTFE : NF C 32-070/C1



Extra-flexible



RoHS

## Hook-up wires for wire-wrapping

Reference NF C 93-522	Nexans Reference	Conductor			Insulation nature	Overall Ø		Average weight Kg/km
		Gauge AWG	Cross section mm <sup>2</sup>	Construction n x Ø mm		mini.	maxi.	
						mm		
<b>KW 01 - 30 C1</b>	<b>WCP 30</b>	30	0.05	1 x 0.254	PVC	0.48	0.58	0.73
<b>KW 01 - 28 C1</b>	<b>WCP 28</b>	28	0.08	1 x 0.32	PVC	0.57	0.67	1.05
<b>KW 01 - 26 C1</b>	<b>WCP 26</b>	26	0.12	1 x 0.40	PVC	0.69	0.79	1.65
<b>KW 01 - 24 C1</b>	<b>WCP 24</b>	24	0.20	1 x 0.51	PVC	1.00	1.10	2.80
<b>KW 02 - 30 B1</b>	<b>WCZ 30</b>	30	0.05	1 x 0.254	ETFE	0.48	0.58	0.79
<b>KW 02 - 28 B1</b>	<b>WCZ 28</b>	28	0.08	1 x 0.32	ETFE	0.57	0.67	1.12
<b>KW 02 - 26 B1</b>	<b>WCZ 26</b>	26	0.12	1 x 0.40	ETFE	0.69	0.79	1.85
<b>KW 02 - 24 B1</b>	<b>WCZ 24</b>	24	0.20	1 x 0.51	ETFE	1.00	1.10	2.90
<b>KW 03 - 30 A2</b>	<b>WCT 30</b>	30	0.05	1 x 0.254	PTFE	0.48	0.58	0.88
<b>KW 03 - 28 A2</b>	<b>WCT 28</b>	28	0.08	1 x 0.32	PTFE	0.57	0.67	1.25
<b>KW 03 - 26 A2</b>	<b>WCT 26</b>	26	0.12	1 x 0.40	PTFE	0.69	0.79	1.90
<b>KW 03 - 24 A2</b>	<b>WCT 24</b>	24	0.20	1 x 0.51	PTFE	1.00	1.10	3.30

For connections on automatic machines, we manufacture these wires with smaller dimensional tolerances. Please, consult us.



**PART 4**  
**Accessories**



# FITE

## Tinned copper flat braids

### Applications

Mainly for connections of mobile contacts, shunts and earthing of mobile equipment (doors, chassis, etc...).

The very thin strands used to manufacture these braids make them extremely flexible and give them an excellent flex life.

### Flat braids

### Construction

Braids made up of tinned copper wires.

These braids are ribbon-like structures (only one ribbon) up to FITE 10.

They are flattened (crushed cylinder) for greater sizes.



### Standards

NEXANS specification



Extra-flexible



RoHS

## ■ FITE - Tinned copper flat braids

Nexans Reference	Construction n x Ø mm	Cross section area mm <sup>2</sup>	Approximate dimensions mm	Average weight Kg/km	Current rating A
<b>FITE 01</b>	26 x 0.12	0.29	2.0 x 0.3	3	3
<b>FITE 02</b>	26 x 0.15	0.46	3.0 x 0.4	4	6
<b>FITE 03</b>	26 x 0.20	0.81	4.0 x 0.6	8	9
<b>FITE 04</b>	39 x 0.20	1.22	4.5 x 0.6	12	12
<b>FITE 05</b>	78 x 0.20	2.45	7.0 x 0.7	25	25
<b>FITE 06</b>	104 x 0.20	3.26	8.0 x 1.0	32	32
<b>FITE 07</b>	130 x 0.15	2.30	6.5 x 0.7	22	21
<b>FITE 08</b>	195 x 0.15	3.44	8.0 x 1.0	35	32
<b>FITE 09</b>	260 x 0.15	4.60	9.0 x 1.0	45	38
<b>FITE 10</b>	390 x 0.15	6.90	11.0 x 1.5	70	50
<b>FITE 11</b>	736 x 0.15	13.00	16.0 x 2.0	130	80
<b>FITE 12</b>	352 x 0.20	11.10	15.0 x 2.0	113	70
<b>FITE 13</b>	384 x 0.25	18.80	21.0 x 2.5	198	116
<b>FITE 14</b>	480 x 0.25	23.50	22.0 x 2.5	235	144
<b>FITE 15</b>	960 x 0.20	30.20	25.0 x 3.0	300	160
<b>FITE 16</b>	800 x 0.20	25.10	20.0 x 2.5	250	150

## TUBULAR BRAIDS

in tinned copper  
without filler

### Applications

Physical and electrical protection for cable bundles.

The diameter of these braids may vary thanks to their very high flexibility, thus facilitating the bundle introduction.

### Tubular braids

### Construction

Tubular braid made up of tinned copper wires.



### Standards

NEXANS specification



Extra-flexible



RoHS

## ■ Tubular braids in tinned copper without filler

Internal Ø nominal mm	Construction n x Ø mm	Cross section area mm <sup>2</sup>	Increases overall diameter	Average weight Kg/km
<b>4</b>	112 x 0.20	3.5	0.8	35
<b>6</b>	144 x 0.20	4.5	0.8	45
<b>8</b>	192 x 0.20	6.0	0.8	60
<b>10</b>	192 x 0.25	9.4	1.0	94
<b>12</b>	224 x 0.25	11	1.0	110
<b>15</b>	256 x 0.25	12.6	1.0	135
<b>19</b>	320 x 0.25	15.7	1.0	165

# TUBULAR BRAIDS

in tinned copper  
with filler

## Applications

Physical and electrical protection for cable bundles.

The central filler prevents any deformation of the braid and is withdrawn when introducing the bundles.

## Tubular braids

## Construction

Tubular braid made up of tinned copper wires around a central filler.

Nota : The cover factor is about 75 % ( $K_r = 0,75$ ) or 80 % ( $K_r = 0,80$ ) according to NF C 93-521 § 1.7.5. French specification.



## Standards

NEXANS specification



Extra-flexible



RoHS

## ■ Tubular braids in tinned copper with filler

Nexans Reference	Internal Ø mm	Overall Ø mm	Covering coefficient Kr	Average weight Kg/km	Nominal cross section mm <sup>2</sup>
<b>55 304/1</b>	4	4.5	0.80	15.0	1.37
<b>55 306/1</b>	6	6.5	0.80	22.0	2.00
<b>55 308/1</b>	8	8.5	0.80	29.0	2.60
<b>55 310/1</b>	10	10.5	0.80	36.0	3.40
<b>55 312/1</b>	12	12.5	0.80	44.0	4.00
<b>55 315/1</b>	15	15.5	0.80	54.0	5.00
<b>55 955/1</b>	18	18.5	0.80	79.0	7.20
<b>55 320/1</b>	20	20.8	0.80	108.0	9.60
<b>59 956/1</b>	22	22.8	0.80	120.0	11.30
<b>59 957/1</b>	25	26.0	0.80	182.0	17.60
<b>59 958/1</b>	30	31.0	0.80	218.0	20.00

# TUBULAR SUPERPOLYAMIDE BRAIDS

High temperature

## Applications

Mechanical protection of cables without any faradization screen.  
Very high toughness.  
Very significant breaking load.  
Very good abrasion resistance.  
Lightweight in comparison with corresponding copper braid or steel braid.

## Tubular braids

## Construction

Tubular braid made up of superpolyamide strands.



## Standards

NEXANS specification

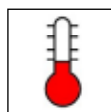

+135 °C max



Extra-flexible

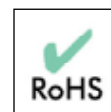

RoHS

## ■ Tubular superpolyamide braids, high temperature

Internal Ø nominal mm	Construction n x Ø mm	Increases overall diameter mm	Average weight Kg/km
<b>3</b>	32 x 0.29	1.2	4.7
<b>4</b>	72 x 0.29	1.2	6.7
<b>6</b>	96 x 0.29	1.2	9.0
<b>8</b>	128 x 0.29	1.2	13.0
<b>10</b>	160 x 0.29	1.2	18.0
<b>12</b>	192 x 0.29	1.2	21.0
<b>15</b>	200 x 0.29	1.2	25.0
<b>18</b>	240 x 0.29	1.2	28.0
<b>20</b>	288x 0.29	1.2	35.0
<b>25</b>	336 x 0.29	1.2	41.0
<b>30</b>	224 x 0.40	1.6	64.0
<b>35</b>	280 x 0.40	1.6	70
<b>40</b>	335 x 0.40	1.6	80.0

# TUBES

## Extruded PTFE

### Applications

These flexible tubes are used for insulation and mechanical protection of cores. They are recommended for use at high ambient temperatures up to 300°C at peak.

Very good resistance to fluids (oil, skydrol, petrol, isopropyl alcohol, kerosene) and most solvents. Mould and Fungus Resistant. They are waterproof and fire retardant.

### Tubes

### Construction

Tube in extruded polytetrafluorethylene (PT.FE.)



### Standards

NEXANS specification

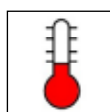

- 90°C to +250°C



Fire retardant  
(NF C 32-070/C1)



Ultra-flexible



RoHS

## PTFE tubes

Gauge AWG	Internal Ø			Radial thickness (mm)	Tolerance +/- (mm)	Nominal external Ø (mm)	Average weight (Kg/km)
	minimum (mm)	nominal (mm)	maximum (mm)				
<b>30</b>	0.25	0.30	0.38	0.23	0.05	0.76	0.9
<b>28</b>	0.33	0.38	0.48	0.23	0.05	0.84	1.0
<b>26</b>	0.41	0.46	0.56	0.23	0.05	0.91	1.1
<b>24</b>	0.51	0.56	0.69	0.25	0.08	1.07	1.5
<b>22</b>	0.64	0.77	0.81	0.25	0.08	1.28	1.7
<b>21</b>	0.74	0.81	0.91	0.25	0.08	1.32	1.9
<b>20</b>	0.81	0.86	1.01	0.31	0.08	1.47	2.5
<b>19</b>	0.91	0.97	1.11	0.31	0.08	1.58	2.7
<b>18</b>	1.02	1.07	1.24	0.31	0.08	1.68	2.9
<b>17</b>	1.14	1.19	1.37	0.31	0.08	1.80	3.1
<b>16</b>	1.30	1.35	1.55	0.31	0.08	1.96	3.5
<b>15</b>	1.45	1.50	1.70	0.31	0.08	2.11	3.8
<b>14</b>	1.63	1.68	1.88	0.31	0.08	2.29	4.2
<b>13</b>	1.83	1.93	2.08	0.31	0.08	2.54	4.8
<b>12</b>	2.06	2.16	2.31	0.31	0.08	2.77	5.2
<b>11</b>	2.31	2.41	2.56	0.31	0.08	3.02	5.7
<b>10</b>	2.59	2.70	2.84	0.31	0.08	3.31	6.4
<b>9</b>	2.90	3.00	3.15	0.38	0.08	3.76	8.9
<b>8</b>	3.28	3.38	3.58	0.38	0.08	4.14	9.7
<b>7</b>	3.66	3.76	4.01	0.38	0.08	4.52	11.0
<b>6</b>	4.11	4.21	4.52	0.38	0.08	4.97	12.1
<b>5</b>	4.62	4.72	5.03	0.38	0.08	5.48	13.4

## Equivalence table of U.S. wire gauges for diameters and cross section areas

GAUGES	DIAMETERS*		CROSS SECTION AREAS		D.C. RESISTANCES AT 20°C	
	AWG	Mils	mm	Circ. mils	sq. mm (mm <sup>2</sup> )	Ohm / kFt
44	2,0	0,050	4,00	0,0020	2590,0	8498,00
43	2,2	0,055	4,84	0,0025	2140,0	7021,00
42	2,5	0,063	6,25	0,0032	1660,0	5446,00
41	2,8	0,071	7,84	0,0039	1320,0	4330,00
40	3,1	0,079	9,61	0,0049	1080,0	3540,00
39	3,5	0,089	12,30	0,0062	847,0	2780,00
38	4,0	0,102	16,00	0,0081	648,0	2130,00
37	4,5	0,114	20,30	0,0103	512,0	1680,00
36	5,0	0,127	25,00	0,0127	415,0	1360,00
35	5,6	0,142	31,40	0,0159	331,0	1080,00
34	6,3	0,160	39,70	0,0201	261,0	587,00
33	7,1	0,180	50,40	0,0255	206,0	675,00
32	8,0	0,203	64,00	0,0324	162,0	532,00
31	8,9	0,226	79,20	0,0401	131,0	430,00
30	10,0	0,254	100,00	0,0507	104,0	340,00
29	11,3	0,287	128,00	0,0649	81,20	266,00
28	12,6	0,320	159,00	0,0806	65,30	214,00
27	14,2	0,361	202,00	0,1020	51,40	169,00
26	15,9	0,404	253,00	0,1280	41,00	135,00
25	17,9	0,455	320,00	0,1620	32,40	106,00
24	20,1	0,511	404,00	0,2050	25,70	84,20
23	22,6	0,574	511,00	0,2590	20,30	66,60
22	25,3	0,643	640,00	0,3240	16,20	53,20
21	28,5	0,724	812,00	0,4110	12,80	41,90
20	32,0	0,813	1.020	0,5190	10,10	33,20
19	35,9	0,912	1.290	0,6530	8,05	26,40
18	40,3	1,020	1.620	0,8230	6,39	21,00
17	45,3	1,150	2.050	1,0400	5,05	16,60
16	50,8	1,290	2.580	1,3100	4,02	13,20
15	57,1	1,450	3.260	1,6500	3,18	10,40
14	64,1	1,630	4.110	2,0800	2,52	8,28
13	72,0	1,830	5.180	2,6300	2,00	6,56
12	80,8	2,050	6.530	3,3100	1,59	5,21
11	90,7	2,300	8.230	4,1700	1,26	4,14
10	101,9	2,588	10.380	5,2600	0,9988	3,277
9	114,4	2,906	13.090	6,6300	0,7925	2,600
8	128,5	3,264	16.510	8,3700	0,6281	2,061
7	144,3	3,655	28.820	10,5500	0,4981	1,634
6	162,0	4,115	26.240	13,3000	0,3952	1,296
5	181,9	4,620	33.090	16,7700	0,3134	1,028
4	204,3	5,189	41.740	21,1500	0,2485	0,8152
3	229,4	5,827	52.620	26,6700	0,1971	0,6466
2	257,6	6,543	66.360	33,6200	0,1563	0,5128
1	289,3	7,348	83.690	42,4100	0,1239	0,4065
1/0	324,9	8,252	105.600	53,4900	0,09825	0,3223
2/0	364,8	9,266	133.100	67,4300	0,07793	0,2557
3/0	409,6	10,400	167.800	85,0100	0,06182	0,2028
4/0	460,0	11,680	211.600	107,2200	0,04901	0,1608

\*Nominal diameter of solid bare copper wire



This catalogue shows a general description of products whose characteristics are not contractual in any way whatsoever. Nexans reserves the right to change specifications without prior notice. Passing on or copying of the document, use or communicate of its content is not permitted without prior written authorization.





## **Global expert in cables and cabling systems**

**With energy as the basis of its development, Nexans, the worldwide leader in the cable industry, offers an extensive range of cables and cabling systems. The Group is a global player in the infrastructure, industry and building markets. Nexans addresses a series of market segments from energy, transport and telecom networks to shipbuilding, oil and gas, nuclear, automotive, electronics, aeronautics, handling and automation.**

**With an industrial presence in more than 30 countries and commercial activities worldwide, Nexans employs 21,000 people and had sales in 2006 of 7.5 billion euros. Nexans is listed on the Paris stock exchange, compartment A of the Eurolist of Euronext. More information on <http://www.nexans.com/>**



140, rue Eugène Delacroix - BP1 - 91211 Draveil Cedex France

Tel : + 33 (0)1 69 83 78 00 - Fax : +33 (0)1 69 42 05 70

[Electronic.products@nexans.com](mailto:Electronic.products@nexans.com) - [www.nexans.com](http://www.nexans.com)